

86TH ANNUAL MEETING



31 JULY-4 AUGUST | PHILADELPHIA, PA, USA

Dear Exhibitor:

As the Official General Service Contractor, we would like to welcome you to the **86th Annual Meeting of the Academy of Management**.

We have, along with Show Management, compiled this Exhibitor Services Manual to provide you with all of the necessary forms and vital information that you will need for a successful exposition experience.

In order to qualify for discount prices where available, please take time to review this manual now. To receive the discount prices your order(s) along with full payment must be received by the date indicated on the particular form. Please do not miss out on this opportunity to secure discounted prices. The savings offered to you are substantial.

Should you have any questions regarding any of the services or need assistance in planning your exhibit, please do not hesitate to contact our customer service department at 253 437 0031 or via email at operations@levyexpo.com. We will be happy to assist you in any way possible to ensure that you have a successful experience at the **86th Annual Meeting of the Academy of Management**.

Thank you and we look forward to servicing your needs at the **86th Annual Meeting of the Academy of Management in Philadelphia, PA**.

Sincerely,

Levy Exposition Services, Inc.



86th Annual Meeting of the Academy of Management

SERVICE CONTRACTOR CONTACT: LEVY EXPOSITION SERVICES INC.
14900 Interurban Avenue S., Suite 271
Seattle, WA 98168
T: 253 437 0031 F: 253 437 0032 E: operations@levyexpo.com

LOCATION: Pennsylvania Convention Center - Hall A
1101 Arch Street
Philadelphia, PA 19107

EXHIBITOR MOVE-IN: Friday, July 31, 2026 8:00 am – 4:00 pm

EXHIBITION DATES: Friday, July 31, 2026 6:00 pm – 8:00 pm
Saturday, August 1, 2026 8:00 am – 5:00 pm
Sunday, August 2, 2026 8:00 am – 5:00 pm

EXHIBITOR MOVE-OUT: Sunday, August 2, 2026 5:00 pm – 8:00 pm

*****Please note that all exhibit materials must be removed from the exhibit Facility by 8:00 pm on Sunday, August 2, 2026*****

BOOTH EQUIPMENT: Each 10' x 10' booth space includes the following:
• 8' high drapery backwall – blue & white
• 3' high drapery sidewall – blue
• 1 - 7" x 44" booth identification sign

If you require additional furnishings or services please complete and return the appropriate enclosed order form(s).

BOOTH CARPET: To maintain a consistent and professional appearance on the show floor, the 86th Annual Meeting of the Academy of Management show rules **require** that that entire contracted exhibit space in all exhibitor booths have carpeting or an alternative floor covering. If you are not bringing your own carpeting or floor covering, please see the Levy Carpet Order Forms for options and ordering.

AISLE CARPET: The aisles will be carpeted in the color blue.

CEILING HEIGHT: The ceiling height in the exhibit hall is 30' feet.

DISCOUNT PRICE DEADLINE: In order to receive the discount rates listed on the enclosed order forms, your **PAID** order is to be received by **July 16, 2026**.

LEVY ONLINE ORDERING (LOLO): The online ordering link and instructions will be sent via email to all exhibitors. Please provide your correct contact information to the show organizer to ensure you receive all necessary show information.

AUDIO VISUAL SERVICES Projection is the official service provider for Audio Visual services. To order services, please see **pages 72 - 75** of the exhibitor kit for the order form.

CONVENTION CENTER SERVICES: The Pennsylvania Convention Center is the official service provider for a variety of services including Electrical, Internet, Telephones, Plumbing and Motor & Truss Rigging. Order forms can be found on **pages 76 - 88**.

QUICK FACTS



86th Annual Meeting of the Academy of Management

QUICK FACTS

CATERING SERVICES: Aramark is the official service provider for Catering services. To order services, please see **pages 89 – 96**.

SHIPPING: Please refer to the Material Handling order form in this manual for further information and associated costs.

All ADVANCE WAREHOUSE shipments should arrive between June 30, 2026 – July 23, 2026. Shipments arriving before or after these dates will incur an early/late surcharge.

Shipments sent to the advance warehouse should be consigned as follows:
(Labels are provided in the Material Handling Section of the manual)

86th Annual Meeting of the Academy of Management
Exhibiting Company Name
Booth # ____
Levy Exposition Services, Inc.
c/o LibertyCFS
1618 Union Ave
Pennsauken, NJ 08110

All **DIRECT** shipments should not arrive prior to 8:00 am on **Friday, July 31, 2026**. Shipments arriving prior to this time will be refused.

Direct shipments should be consigned as follows:
(Labels are provided in the Material Handling section of manual)

86th Annual Meeting of the Academy of Management
Exhibiting Company Name
Booth # ____
Pennsylvania Convention Center
c/o Levy Exposition Services, Inc.
1101 Arch Street
Philadelphia, PA 19107

DISMANTLE AND MOVE-OUT INFORMATION:

All exhibitor materials **MUST** be removed from the facility by 8:00 pm on Sunday, August 2, 2026. To ensure that all exhibitor materials are removed by this time, please have your carrier check in no later than 6:00 pm on Sunday, August 2, 2026. In the event that your carrier does not check-in by this time, your shipment will be rerouted via the official carrier, Liberty CFS NV, Inc.

POST SHIPPING PAPERWORK:

Our customer service center will have outbound bills of lading and shipping labels for your convenience. Please note that Levy Exposition Services Bills Of Lading's (BOLs) **MUST** be filled out and turned into the service center once your materials are packed for all outbound shipments. It is vital that your carrier knows your company name and booth # when you make your outbound shipping arrangements. Additionally, if your carrier plans to use a freight forwarding company to pick up your shipment(s), you **MUST** include this company's name as well as the actual shipping company's name on the bill of lading that you fill out. In the event someone other than the company listed on your outbound bill of lading arrives to pick up your shipment, it will be rerouted via the official show carrier.

Loading Docks:

Docks A, B, C, D, E, Grand Hall & Ballroom A&B:

Access ramp is located East bound on Vine Street between 12th and 11th Streets

GPS Address: 1130 Vine Street Philadelphia Pennsylvania 19107

Dock F: Once on 12th drive one block make a left onto Race Street the loading dock entrance is located half way down the block on the right side.

GPS Address: 1140 Race Street Philadelphia Pennsylvania 19107

Dock G: Once on 12th drive two blocks to Arch Street. Make a right onto Arch Street go one block to 13th Street turn left the entrance is located on the left hand side towards the end of the block.

GPS Address: 151 North 13th Street Philadelphia Pennsylvania 19107

House Dock:

Once on 12th drive two blocks to Arch Street. Make a right onto Arch go one block to 13th Street make a right. Drive one block to Race Street and make a right. The entrance is halfway down the block between 13th and 12th.

GPS Address: 1260 Race Street Philadelphia Pennsylvania 19107

From I-95 Southbound, New York, Northern & Central New Jersey, New England

Take I-95 South to Exit 22 for Central Philadelphia I-676. Stay in the left lane of this exit. Follow signs for 676 West to the 1st exit (Broad Street). This exit brings you up onto 15th St.

From I-95 Northbound, Philadelphia International Airport, Baltimore, Washington and Delaware

Take I-95 North to Exit 22 for Central Philadelphia I-676. Stay in the left lane of this exit. Follow signs for 676 West to the 1st exit (Broad Street). This exit brings you up onto 15th St.

To Pennsylvania Convention Center Entrances via the above I-95 routes

Main Entrance 12th & Arch

Halls A, B, C, F, Grand Hall & Ballroom A&B: Proceed to 2nd light and make a left onto Vine St. East. Take Vine Street to 12th St. make a right on to 12th. Drive straight ahead two blocks to Arch Street.

GPS Address: 1201 Arch Street Philadelphia Pennsylvania 19107

Broad Street Entrance (Broad between Race and Arch)

Halls D, E, G, Broad Street Atrium & Terrace Ballroom: Proceed to 2nd light and make a left onto Vine St. East. Take Vine Street to 12th St; make a right on to 12th. Drive straight ahead two blocks to Arch Street. Make a right onto Arch go 3 blocks to Broad Street make a right. Entrance is between Arch and Race.

GPS Address: 119 North Broad Street Philadelphia Pennsylvania 19107

Loading Docks:

Docks A, B, C, D, E, Grand Hall & Ballroom A&B: (entrance on Vine Street Eastbound between 12th and 11th Street) Proceed to 2nd light and make a left onto Vine St. East. Take Vine Street to ramp which is located East bound on Vine Street between 12th and 11th Streets

GPS Address: 1130 Vine Street Philadelphia Pennsylvania 19107

ONLINE ORDERING INSTRUCTIONS

We are pleased to offer online ordering for the **86th Annual Meeting of the Academy of Management**. This system is designed to assist in fulfilling your exposition needs simply, conveniently and securely.

Our online ordering links are unique to each exhibitor and are generated when exhibitors are imported to our online system. This creates a streamlined experience for exhibitors and eliminates the need to create a username and password.

1. You will receive an email from Levy Exposition Services with a copy of the PDF Exhibitor Kit and your account specific online ordering link.
NOTE: If you do not receive your email, please email agaudet@levyshow.com and you will be sent one directly.



2. Once you have accessed the online ordering portal, you will be directed to the Welcome Page where you can access the Exhibitor Kit, Show Facts and other ancillary service forms. To begin online ordering, you can click the red "Order Booth Services" button. 
5. After making your service or rental selections, click the "Add to Cart" button. Once you have finished adding all items or services to your cart, click on the "My Cart/Orders" tab on the menu at the top of the page to view your order.
6. To complete your purchase click on the "Proceed to Checkout" button.
7. Complete your billing details and enter your credit card information to confirm and complete the order.
NOTE: Alternatively, to expedite the check out process, you may enter your card details before online shopping by clicking the "My Profile/CC" tab on the menu at the top of the page, then click "Credit Cards" and fill out the required information.

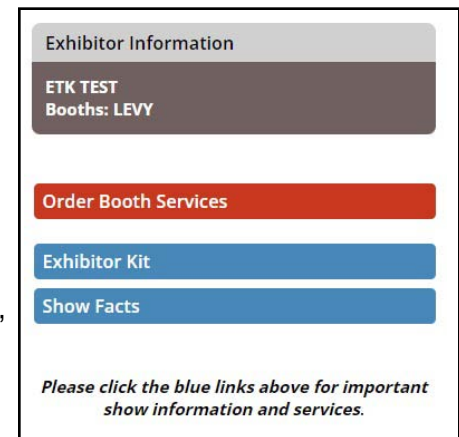

OTHER HELPFUL INFORMATION:

1. To find your username and password, please click on the "My Profile/CC" tab on the menu at the top of the page.
2. To access and view your invoice(s), please click on the "My Invoice" tab on the menu at the top of the page.

SAFETY RULES

Exhibitors must provide adequate space within the exhibit to allow for the comfort and safety of persons watching demonstrations and/or placing orders. Each exhibitor is responsible for keeping the aisles near their booth free of congestion which may be caused by such demonstrations and/or order placement.

Aisles **MUST** remain free and clear of all obstructions. If chairs are being used as part of your exhibit, they **MUST** remain inside your booth space. Chairs in the aisle constitute a violation of fire codes and are also considered a booth violation.

Do not run electrical cords or position displays and/or product in such a way as to pose a safety hazard for attendees and company personnel who will traffic into booth areas.

Do not store cardboard cartons or packing materials in booth areas, as this is a violation of fire codes and poses a safety hazard.

Do not place product samples, whether on tables or free-standing displays, at the edge of the aisle, or in the case of an island booth, on shelving units on an outside wall. All portions of an Exhibitor's display must be contained within his/her assigned booth space, including chairs placed at the edge of an aisle.

At the close of the exhibit hall, please keep clear of all aisles including exhibit material and/or product. During the first two or three hours after the close of the exhibit hall, there is ample traffic in the aisles including but not limited to forklift traffic returning empty containers.

SHOW SITE WORK RULES IN PENNSYLVANIA

To assist you in planning your participation in your show, we are certain you will appreciate knowing in advance that union labor will be required for certain aspects of your exhibit handling.

LABOR

Loading, unloading, forklift operation, installation and dismantling of drapery and furniture and the movement of freight, empties and Contractor equipment. Deliver and pick up rolled carpet, including specialty carpet and contractor's carpet. Sort, distribute, install, and remove table topping and skirting of Contractor's tables.

ELECTRICIANS

Electricians are primarily responsible for work relating to electrical systems; handling and installing suspended electric motors, truss, lights, and signage; power supply and distribution, including hookups and interconnections; lighting and data, handling and installing computers and network cabling; maintenance of equipment and power; disconnect and reconnect battery terminals in vehicles on the show floor.

PLUMBERS

Provide plumbing, compressed air, water, and drains.

RIGGERS

Riggers are primarily responsible for work relating to the lifting or moving of objects which require mechanical lifting. Riggers work includes:

- A.** Operate forklifts with respect to machinery and equipment that requires specialized lifting or handling.
- B.** Operate forklifts for rigging in exhibit booths and moves crates within exhibit booth space associated with the performance of their work.
- C.** Move oversized or abnormally heavy objects.
- D.** Raise and lower oversized or heavy exhibit booth structures.
- E.** Operate and utilize genie lifts as required.

STAGEHANDS

Lay, and remove all floor coverings; including Exhibitor owned booth carpet, install and dismantle exhibit booth structures, install, dismantle, operate, and handle Audio Visual equipment used in exhibit booths when supplied by an Audio-Visual Contractor.

Full time employees of the Exhibiting Company can set up/dismantle their own booths of any size unless they hire an EAC or order display labor through LEVY.

GRATUITIES

Our work rules prohibit the SOLICITATION OR ACCEPTANCE of tips in cash, product, or gifts in kind by any employee (union or non-union). Our employees are paid appropriate wages denoting professional status, therefore tipping of any kind is not allowed.

WORK ZONE

Customer acknowledges that the show site and surrounding areas are active work zones. Customer, its agents, employees, and representatives are present at their own risk.

EXHIBIT CONSTRUCTION GUIDELINES SUMMARY

The Exhibitor's responsibility can be summed up as simply: **"Be a good neighbor!"** All exhibitors are equal regardless of size and should be given an equal opportunity, within reason, to present their product in the most effective manner to the audience.

STANDARD BOOTH

Linear Booths have only one side exposed to an aisle and are generally arranged in a series along a straight line. They are also called "in-line" booths.

Dimensions: Linear Booths are most commonly ten feet (10') wide and ten feet (10') deep, i.e. 10'x10'. A maximum back wall height limitation of height feet (8') is generally specified.

Use of Space: Regardless of the number of Linear Booths utilized, (e.g. 10'x20', 10'x30', 10'x40', etc.) Display materials should be arranged in such a manner so as not to obstruct sight lines of neighboring exhibitors.

The maximum height of eight feet (8') is allowed only in the rear half of the booth space, with a four-foot (4') height restriction imposed on all materials in the remaining space forward to the aisle.

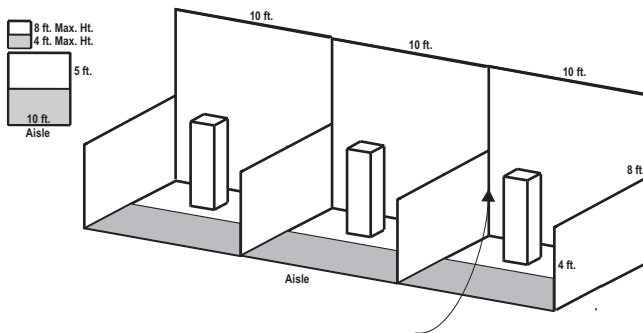

One or more standard 10'x10' units in a straight line.

Note: Booth drape is set at 8 ft max.

Display fixtures over 4 ft high must be confined to that area that is at least 5 ft from the aisle line.

PENINSULA END-CAP BOOTH

An end cap booth is exposed to aisles on three sides and composed of two booths.

Dimensions: End-cap Booths are generally ten feet (10') deep by twenty feet (20') wide. The maximum back wall height of eight feet (8') is allowed only in the rear half of the booth space and within five feet (5') of the two side aisles with a four foot (4') height restriction imposed on all materials in the remaining space forward to the aisle.

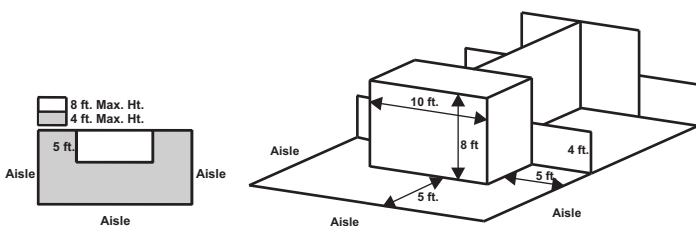

HANGING SIGN BOOTH

An exhibit component suspended above an exhibit of four or more standard units back-to-back with an aisle on at least three sides for the purpose of displaying graphics or identification.

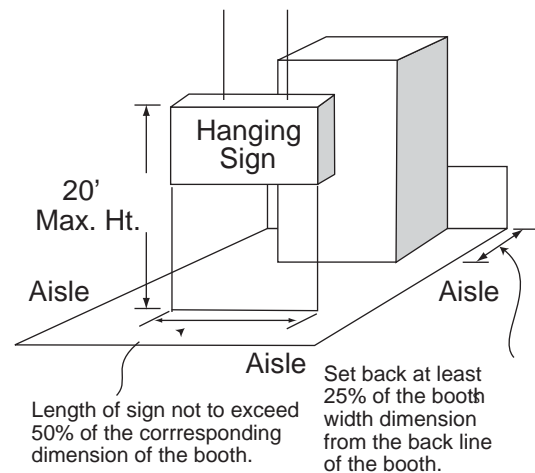

****All overhead signs must be assembled, installed and removed by Levy. Please complete the enclosed labor order form for labor to assemble your hanging sign****

ISLAND BOOTH

An Island Booth is any size booth exposed to aisles on all four sides.

Dimensions: An Island Booth is 20' x 20' or larger, although it may be configured differently.

Use of Space: The entire cubic content of the space may be used up to the maximum allowable height, which is usually sixteen feet (16'), including signage.

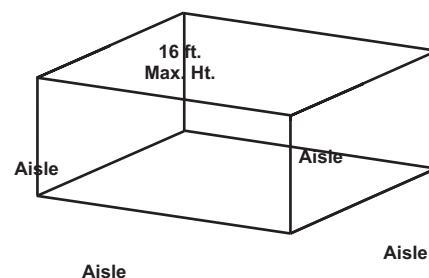

Please note that the ceiling height in the Exhibit Hall is 30 feet.



Fax: 253 437 0032
 14900 Interurban Avenue South, Suite 271
 Seattle, WA
 USA 98168
 Telephone: 253 437 0031
 E-mail: operations@levyexpo.com

**86th Annual Meeting of the
 Academy of Management
 July 31 - August 4, 2026
 Pennsylvania Convention Center
 Philadelphia, PA**

THIRD PARTY BILLING REQUEST

COMPANY	BOOTH NUMBER	Deadline Date July 16, 2026
ADDRESS <small>street city state/province zip/postal code country</small>		
PHONE <small>FAX</small>	PURCHASE ORDER NUMBER	<i>All orders are regulated by LES Payment Terms & Conditions as well as Material Handling Terms & Conditions.</i>
AUTHORIZED CONTACT SIGNATURE X	AUTHORIZED CONTACT - PLEASE PRINT DATE	

You may arrange for a third party to handle your display and be billed for services. LES will agree to this arrangement if the third party has a satisfactory payment record with us. BOTH firms must complete this form, and the **THIRD PARTY must complete the credit card charge authorization on the *Payment & Credit Card Authorization form***. Return both forms by the deadline date.

It is understood and agreed that the exhibiting firm is ultimately responsible for payment of charges. If your named third party does not pay the invoice before the last day of the show, charges will revert to you, the exhibiting firm. All invoices are due and payable upon receipt.

EXHIBITING FIRM

EXHIBITING FIRM

ADDRESS

CITY STATE/PROVINCE ZIP/POSTAL CODE

PHONE FAX

AUTHORIZED SIGNATURE

THIRD PARTY

THIRD PARTY

ADDRESS

CITY STATE/PROVINCE ZIP/POSTAL CODE

PHONE FAX

AUTHORIZED SIGNATURE

ALL LES SERVICES WILL BE INVOICED TO THE THIRD PARTY UNLESS INDICATED BELOW:

EXHIBITING FIRM'S CREDIT CARD CHARGE AUTHORIZATION

CARDHOLDER'S BILLING ADDRESS

CITY PROV. / STATE

POSTAL/ZIP CODE COUNTRY

TODAY'S DATE MONTH / DAY / YEAR

CARD NUMBER

VISA MASTERCARD AMEX CHECK

EXPIRY DATE CVCC

CARDHOLDER NAME
(PLEASE PRINT) _____

SIGNATURE _____



Fax: 253 437 0032
 14900 Interurban Avenue South, Suite 271
 Seattle, WA
 USA 98168
 Telephone: 253 437 0031
 E-mail: operations@levyexpo.com

**86th Annual Meeting of the
 Academy of Management
 July 31 - August 4, 2026
 Pennsylvania Convention Center
 Philadelphia, PA**

REQUEST FOR SET-UP BY NON-OFFICIAL CONTRACTOR

The unpacking, erection, assembling, dismantling, and packing of displays and equipment must be done by the correct type of labor. Levy Exposition Services Inc., the official contractor, will have skilled craftsmen available to assist Exhibitors. Arrangements for labor should be made through Levy Exposition Services in advance whenever possible. Official labor forms are included in the Exhibitor Service Manual.

Exceptions to the foregoing will be considered only in cases where permission has been requested in writing by the Exhibitor and **received by Levy Exposition Services Inc. no later than July 16, 2026.** Exceptions will be granted only if it will not interfere with or prejudice the orderly set-up, interim service, or dismantling of the Exposition. An exception will not be granted if it is inconsistent with the commitments made and obligations assumed by Management in any contract with service contractors or its lease with the **Pennsylvania Convention Center.** For services such as electrical, plumbing, telephone, drayage, rigging and booth cleaning, no exception will be made, and the contractor designated by Management will be used.

All agents representing the Exhibitor must be fully identified by the official Management badge. All agents or representatives who are performing services other than the Exhibitor's own employees must provide Levy Exposition Services with **Certificates of Insurance naming Levy Exposition Services Inc., Academy of Management, 86th Annual Meeting of the Academy of Management and the Pennsylvania Convention Center as additional insured's by July 16, 2026.** These Certificates of Insurance must include public liability and property damage insurance for at least \$1,000,000, and workmen's compensation insurance in accordance with local law.

Exhibitors wishing to use a contractor other than Levy Exposition Services Inc. to set up and dismantle their exhibits must fill out this form and return to us no later than July 16, 2026. If this form and the certificate of insurance from the non-official contractor is not received by July 16, 2026, your non-official contractor will be allowed to supervise only. All labor must then be hired from Levy Exposition Services Inc. for installation and dismantle of the exhibit.

**ORIGINAL CERTIFICATES ONLY
 PHOTOSTATS OR FACSIMILES WILL NOT BE ACCEPTED**

Name of Exhibiting Company: _____ Booth Number: _____

Contracting Company Name: _____

Contracting Company Address: _____

City: _____ State: _____ Zip: _____ Telephone: _____ Fax _____

Estimated Arrival at Show _____ Number of Workers: _____

Authorized By: _____ Title: _____
 (Sign & Print Name)

CARPET and DRAPE

Standard carpet color options



Blue



Red

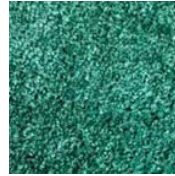

Teal



Grey



Burgundy

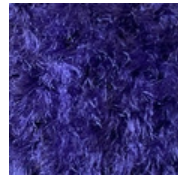

Purple



Black

Drape color options

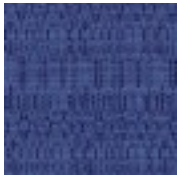

Blue



Red

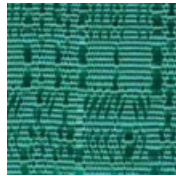

Teal

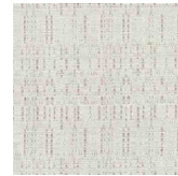

White

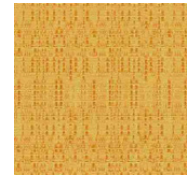

Gold



Black



Purple

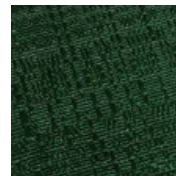

Green



Grey



Burgundy

**DISCLAIMER* Actual products and colors available may vary from the images shown. All products subject to availability*

Do you have questions?

We would be pleased to help. Contact us at: 253 437 0031

operations@levyexpo.com

www.levyexpo.com



Fax: 253 437 0032
 14900 Interurban Avenue South, Suite 271
 Seattle, WA
 USA 98168
 Telephone: 253 437 0031
 E-mail: operations@levyexpo.com

86th Annual Meeting of the
 Academy of Management
 July 31 - August 4, 2026
 Pennsylvania Convention Center
 Philadelphia, PA

CARPET, DRAPE & COMPLEMENTS RENTAL ORDER FORM & INVOICE

COLORED CARPET SELECTIONS

Description	Discount Rate	Standard Rate	Total
Size - 10 ft. X 10 ft.	456.25	593.75	
10 ft. X 20 ft.	912.50	1,186.25	
10 ft. X 30 ft.	1,368.75	1,780.00	
10 ft. X 40 ft.	1,825.00	2,372.50	
Custom cut size. Calculate sq. ft. x price per sq. ft. Size _____ ft. x _____ ft. = _____ sq. ft.	7.25	9.45	

Blue Red Teal Grey Burgundy Purple Black

DRAPE (Includes installation and removal)

_____ lin. ft. of 3' high drape	\$12.50/ft	\$16.75/ft	
_____ lin. ft. of 8' high drape	\$17.85/ft	\$22.50/ft	

Blue Red Teal White Gold Black
 Purple Green Grey Burgundy

CARPET OPTIONS

Description	Discount Rate	Standard Rate	Total
Carpet foam padding per sq. ft. Size _____ ft. x _____ ft. = _____ sq. ft.	3.15	4.75	
Poly covering per sq. ft. Size _____ ft. x _____ ft. = _____ sq. ft.	1.55	1.85	

COMPLEMENTS (Also see Specialty Accessories Form)

Quantity	Description	Discount Rate	Standard Rate	Total
	Waste basket	45.00	58.60	
	Chrome coat tree	195.65	254.40	
	Aluminum easel	77.50	100.65	
	Chrome sign holder 22" X 28"	195.65	254.40	
	Chrome stanchions	45.00	58.55	
	Velvet stanchion ropes - blue	45.00	58.55	

SPECIAL INSTRUCTIONS

EXHIBITOR INFORMATION

COMPANY _____

CONTACT _____

BOOTH#

COST SUMMARY

RATE ADJUSTMENT	(OFFICE USE ONLY)	
25% CANCELLATION FEE	(OFFICE USE ONLY)	
SUBTOTAL		
2.0% CREDIT CARD FEE		
8.0% SALES TAX		
TOTAL	US DOLLARS	

PLEASE REFER TO THE PAYMENT & CREDIT CARD CHARGE AUTHORIZATION FORM

ORDERS WILL NOT BE PROCESSED WITHOUT PAYMENT

STANDARD RATE will be applied to all orders not received and paid in full by **July 16, 2026**. We reserve the right to adjust orders calculated incorrectly.

A 25% CANCELLATION FEE will be applied to all orders received and then canceled. If full service has been provided then 100% of original fee will be applied.

CUSTOM CARPET

Deluxe Decorator 28oz. Carpet color options

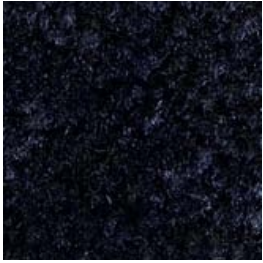

Black



Red



Nu Blue



Silver Cloud



Beige



Charcoal



Key Lime

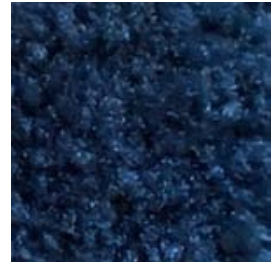

Navy



Cobalt



White

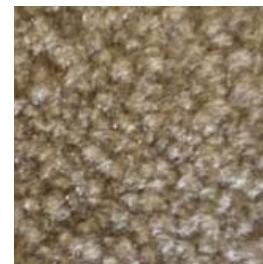

Silky Beige

**DISCLAIMER* Actual products and colors available may vary from the images shown. All products subject to availability*

Do you have questions?

We would be pleased to help. Contact us at: 253 437 0031

operations@levyexpo.com

www.levyexpo.com

CUSTOM CARPET ORDER FORM

Deluxe 28 oz. Carpet in a Variety of Decorator Colors to Enhance Your Exhibit

- | | | |
|---------------------------------------|--------------------------------------|-----------------------------------|
| <input type="checkbox"/> Black | <input type="checkbox"/> Red | <input type="checkbox"/> Nu Blue |
| <input type="checkbox"/> Silver Cloud | <input type="checkbox"/> Beige | <input type="checkbox"/> Charcoal |
| <input type="checkbox"/> Key Lime | <input type="checkbox"/> Navy | <input type="checkbox"/> Cobalt |
| <input type="checkbox"/> White | <input type="checkbox"/> Silky Beige | |

(CHECK BOX OF COLOR DESIRED)
 SAMPLES AVAILABLE UPON REQUEST

Rental includes installation and poly covering for protection and removal.
 Orders must be received by **July 16, 2026** to guarantee availability.

		DISCOUNT PRICE	STANDARD PRICE (late order)
Booth Size	_____ ft. x _____ ft. = _____ sq. Ft. at	\$8.65 per sq. ft.	\$13.80 per sq. ft. =\$_____
Carpet Pad	_____ ft. x _____ ft. = _____ sq. Ft. at	\$3.15 per sq. ft.	\$4.75 per sq. ft. =\$_____

NOTE: Include a floor plan if additional carpet is required to cover steps, skids and display fixtures. A quotation will be forwarded to you before we proceed

SPECIAL INSTRUCTIONS

EXHIBITOR INFORMATION

COMPANY	
CONTACT	BOOTH#

COST SUMMARY

RATE ADJUSTMENT	(OFFICE USE ONLY)	
CANCELLATION FEE	(OFFICE USE ONLY)	
SUBTOTAL		
2.0% CREDIT CARD FEE		
8.0% SALES TAX		
TOTAL	US DOLLARS	

PLEASE REFER TO THE PAYMENT & CREDIT CARD CHARGE AUTHORIZATION FORM

****ORDERS WILL NOT BE PROCESSED WITHOUT PAYMENT****

STANDARD RATE will be applied to all orders not received and paid in full by **July 16, 2026**. We reserve the right to adjust orders calculated incorrectly.

A 25% CANCELLATION FEE will be applied to all orders received then canceled. If full service has been provided then 100% of original fee will be applied.

TABLES & CHAIRS

Tables

All tables are available in the below options:

- Unskirted or Skirted
- 30" or 40" height
- 4', 6', or 8' lengths x 2' widths



4' x 2' skirted table



6' x 2' skirted table



8' x 2' skirted table

Skirt color options

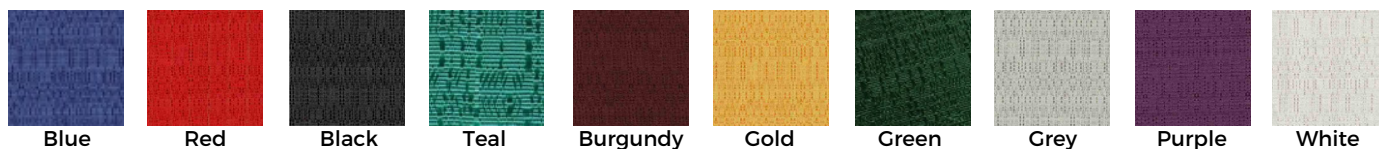

Blue

Red

Black

Teal

Burgundy

Gold

Green

Grey

Purple

White

Pedestal Tables

All pedestal tables are available in the below options:

- 30" diameter tops
- 30" or 40" high



40" high pedestal



30" high pedestal

Chairs



Fabric Sled Base Chair



Fabric Arm Chair



Fabric Highback Stool

**DISCLAIMER* Actual products and colors available may vary from the images shown. All products subject to availability*

Do you have questions?

We would be pleased to help. Contact us at: 253 437 0031

operations@levyexpo.com

www.levyexpo.com

TABLE AND CHAIR RENTAL ORDER FORM & INVOICE

TABLES

Description	Qty.	Discount Rate	Standard Rate	Total
 TABLES 30" HEIGHT				
8' x 2' Skirted		343.75	446.85	
6' x 2' Skirted		318.75	414.40	
4' x 2' Skirted		253.75	329.85	
Fourth side of table skirted		90.00	117.00	
Unskirted table <input type="checkbox"/> 8' <input type="checkbox"/> 6' <input type="checkbox"/> 4'		110.00	143.15	

- Blue Red Black Teal Burgundy
 Gold Green Grey Purple White

 TABLES 40" COUNTER HEIGHT				
8' x 2' Skirted		418.75	544.40	
6' x 2' Skirted		378.75	492.40	
4' x 2' Skirted		316.25	411.15	
Fourth side of table skirted		97.50	130.50	
Unskirted table <input type="checkbox"/> 8' <input type="checkbox"/> 6' <input type="checkbox"/> 4'		122.50	159.25	

- Blue Red Black Teal Burgundy
 Gold Green Grey Purple White

 GREY PEDESTAL TABLE - 30" DIAMETER				
30" Table height		223.75	290.85	
40" Counter height		273.75	355.85	

SPECIAL INSTRUCTIONS

EXHIBITOR INFORMATION

COMPANY

CONTACT

BOOTH#

COST SUMMARY

RATE ADJUSTMENT	(OFFICE USE ONLY)	
CANCELLATION FEE	(OFFICE USE ONLY)	
SUBTOTAL		
2.0% CREDIT CARD FEE		
8.0% SALES TAX		
TOTAL	US DOLLARS	

PLEASE REFER TO THE PAYMENT & CREDIT CARD CHARGE AUTHORIZATION FORM

ORDERS WILL NOT BE PROCESSED WITHOUT PAYMENT

STANDARD RATE will be applied to all orders not received and paid in full by **July 16, 2026**. We reserve the right to adjust orders calculated incorrectly.

A 25% CANCELLATION FEE will be applied to all orders received and then canceled. If full service has been provided then 100% of original fee will be applied.

SPECIALTY ACCESSORIES RENTAL ORDER FORM & INVOICE

DISPLAY UNITS

Description	Qty.	Discount Rate	Standard Rate	Total
FABRIC POSTER BOARD 4' x 8' grey fabric covered both sides <input type="checkbox"/> Horizontal (shown) <input type="checkbox"/> Vertical		180.00	233.75	
POP-UP BOOTH 9'-6" x 7'-5" tall Velcro compatible Set of four lights <input type="checkbox"/> Blue <input type="checkbox"/> Grey <input type="checkbox"/> Black		2,716.85	3,531.85	
BLACK UPRIGHT LITERATURE RACK 6 pockets for 8.5" x 11" material		200.00	260.00	
PLEXIGLASS BROCHURE HOLDER 9" x 11" <input type="checkbox"/> Table top <input type="checkbox"/> Wall mount		57.50	74.75	
ALUMINUM EASEL Fits sign sizes: 22" x 28" 24" x 36" 28" x 44"		77.50	100.65	
CHROME SIGN HOLDER 22" x 28"		195.65	254.40	

ACCESSORIES

TABLE TOP PLEXI DRAW BOX 12" x 12" x 12" tall	90.65	117.25	
<input type="checkbox"/> CHROME CLOTHING STAND <input type="checkbox"/> CHROME BAG HOLDER	195.65	254.40	
CHROME COAT TREE	195.65	254.40	
WASTE BASKET	45.00	58.60	

SPECIAL INSTRUCTIONS

EXHIBITOR INFORMATION

COMPANY

CONTACT

BOOTH#

COST SUMMARY

RATE ADJUSTMENT	(OFFICE USE ONLY)	
25% CANCELLATION FEE	(OFFICE USE ONLY)	
SUBTOTAL		
2.0% CREDIT CARD FEE		
8.0% SALES TAX		
TOTAL	US DOLLARS	

PLEASE REFER TO THE PAYMENT & CREDIT CARD CHARGE AUTHORIZATION FORM

ORDERS WILL NOT BE PROCESSED WITHOUT PAYMENT

STANDARD RATE will be applied to all orders not received and paid in full by **July 16, 2026**. We reserve the right to adjust orders calculated incorrectly.

A 25% CANCELLATION FEE will be applied to all orders received and then canceled. If full service has been provided then 100% of original fee will be applied.

RENTAL EXHIBITS

10' x 10' Hardwall Rental Exhibit Booths

All hardwall packages include the below:

- Aluminum structure
- White
- Header(s) - block letters - black (logo extra)
- 10' x 10' Carpet
- 30" pedestal table (x1)
- Fabric sledbase chairs (x2)

Package A1 Base



Package A2 Deluxe

- Base Package plus the below:
- 10" deep shelves (x2)
- 39" x 20" x 39" counter (x1)

Package B1 Base

- Curved header - block letters - black (logo extra)
- Curved front display counter



Package B2 Deluxe

- Base Package plus the below:
- Enclosed corner counter
- 10" deep shelves (x2)

Package C1 Base

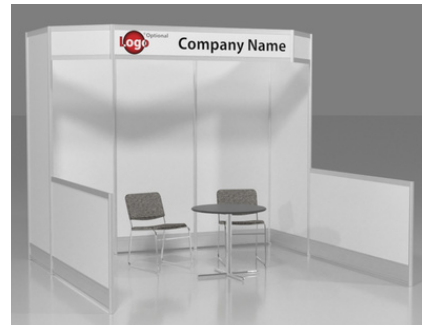

Package C2 Deluxe

- Base Package plus the below:
- 10" deep shelves (x2)
- 39" x 20" x 39" counter (x1)

Package D1 Base

- Oversized header - block letters - black (logo extra)
- 20" x 39" x 39" high built-in counters on backwall (x2)



Package D2 Deluxe

- Base Package plus the below:
- 10" deep shelves (x2)
- 39" x 20" x 39" counter (x1)

**DISCLAIMER* Actual products and colors available may vary from the images shown. All products subject to availability*

Do you have questions?

We would be pleased to help. Contact us at: 253 437 0031

operations@levyexpo.com

www.levyexpo.com

RENTAL EXHIBITS

10' x 20' Hardwall Rental Exhibit Booths

All hardwall packages include the below:

- Aluminum structure
- White
- Header(s) - block letters - black (logo extra)
- 10' x 20' Carpet
- 30" pedestal table (x1)
- Fabric sledbase chairs (x2)

Package E1 Base

- Straight headers (x2)

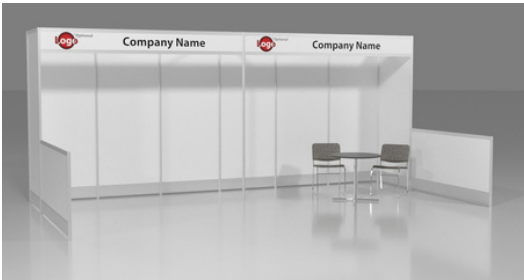

Package E2 Deluxe

- Base Package plus the below:
- 10" deep shelves (x2)
- 39" x 20" x 39" counter (x1)

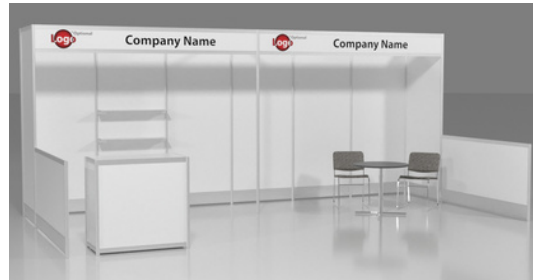

Package F1 Base

- Straight header (x1)
- Angled header (x2)
- Storage area with drape door
- Front built-in corner counters (x2)



Package F2 Deluxe

- Base Package plus the below:
- Lockable door for storage area
- 39" x 20" x 39" counter (x2)



Package G1 Base

- Straight header (x1)
- 39" x 20" x 39" built-in counter (x1)

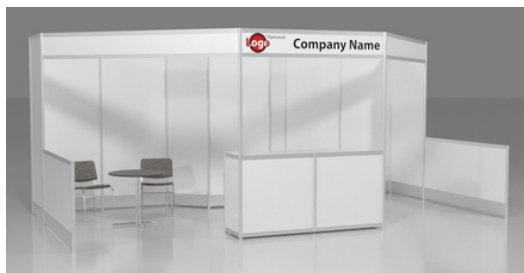

Package G2 Deluxe

- Base Package plus the below:
- 10" deep shelves (x4)

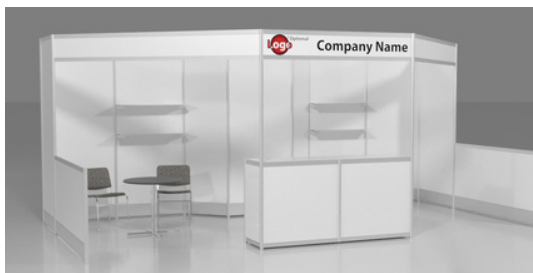

Package H1 Base

- Oversized curved header (x1)
- 39" x 20" x 39" built-in counters (x3)



Package H2 Deluxe

- Base Package plus the below:
- 10" deep shelves (x3)
- 2m curved front counter (x1)

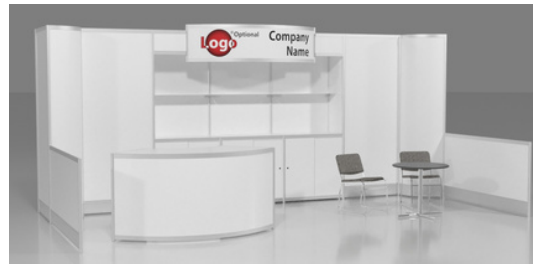

**DISCLAIMER* Actual products and colors available may vary from the images shown. All products subject to availability*

Do you have questions?

We would be pleased to help. Contact us at: 253 437 0031

operations@levyexpo.com

www.levyexpo.com



Fax: 253 437 0032
 14900 Interurban Avenue South, Suite 271
 Seattle, WA
 USA 98168
 Telephone: 253 437 0031
 E-mail: operations@levyexpo.com

**86th Annual Meeting of the
 Academy of Management
 July 31 - August 4, 2026
 Pennsylvania Convention Center
 Philadelphia, PA**

RENTAL EXHIBITS RENTAL ORDER FORM & INVOICE

10' x 10' BOOTH PACKAGES - Please contact customer service for GRAPHIC UPGRADES

Description	Qty	Discount Rate	Standard Rate	Total
Description: Base package includes: Aluminum structure, white hardwalls, booth header with company name in block lettering, carpet, 30" pedestal table, (2) fabric chairs, installation and dismantle.				
PACKAGE A1 Basic - Base package with header		5,995.00	7,793.75	
PACKAGE A2 Deluxe - Base package + (2) 10" deep shelves, (1) 39" x 20" x 39" counter		6,476.25	8,420.00	
PACKAGE B1 Basic - Corner base package booth with curved counter, 1 curved header sign		6,655.00	8,652.50	
PACKAGE B2 Deluxe - Base package + enclosed corner counter, (2) 10" deep shelves		7,026.25	9,135.00	
PACKAGE C1 Basic - Base package with header		6,187.50	8,043.75	
PACKAGE C2 Deluxe - Base package + (2) 10" deep shelves, (1) 39" x 20" x 39" counter		6,943.75	9,027.50	
PACKAGE D1 Basic - Base package with oversized header, (2) built-in back counters		7,142.50	9,367.50	
PACKAGE D2 Deluxe - Base package + (2) 10" deep shelves, (1) 39" x 20" x 39" counter		7,535.00	9,796.25	

10' x 20' BOOTH PACKAGES - Please contact customer service for GRAPHIC UPGRADES

Description	Qty	Discount Rate	Standard Rate	Total
Description: Base package includes: Aluminum structure, white hardwalls, booth header with company name in block lettering, carpet, 30" pedestal table, (2) fabric chairs, installation and dismantle.				
PACKAGE E1 Basic - Base package with headers		10,023.75	13,031.25	
PACKAGE E2 Deluxe - Base package + (2) 10" deep shelves, (1) 39" x 20" x 39" counter		10,906.25	14,177.50	
PACKAGE F1 Basic - Base package with headers, storage and drape door, (2) built-in counters		10,746.25	13,970.00	
PACKAGE F2 Deluxe - Base package + lockable door for storage, (2) 39" x 20" x 39" counters		12,066.25	15,686.25	
PACKAGE G1 Basic - Base package with header, (1) built-in counter		11,385.00	14,801.25	
PACKAGE G2 Deluxe - Base package + (2) 10" deep shelves		12,023.75	15,630.00	
PACKAGE H1 Basic - Base package with oversized curved header, (3) built-in back counters		12,746.25	16,571.25	
PACKAGE H2 Deluxe - Base package + (2) 10" deep shelves, (1) curved front counter		13,742.50	17,865.00	

OPTIONS & INFORMATION

HARDWALL PANEL (non fabric) SELECTION

White

CARPET COLOR SELECTIONS

Grey Red Teal Blue Black Burgundy Purple

HEADER TO READ (up to 20 characters, black lettering on white)

Header One

Header Two

ACCESSORY OPTIONS

Description	Qty.	Discount Rate	Standard Rate	Total
1 meter Angled Shelves		100.00	130.00	
1 meter Shelves		87.50	113.75	
Spot Lights (For use with rental unit)		112.50	146.25	
Literature Pockets 8 1/2" x 11"		50.00	65.00	
Nylon Loop Fabric Panel per sq.ft. <small>**contact for available color options</small>		\$6.56 sq.ft.	\$8.83 sq.ft.	

SPECIAL INSTRUCTIONS

EXHIBITOR INFORMATION

COMPANY

CONTACT

BOOTH#

COST SUMMARY

RATE ADJUSTMENT	(OFFICE USE ONLY)	
25% CANCELLATION FEE	(OFFICE USE ONLY)	
SUBTOTAL		
2.0% CREDIT CARD FEE		
8.0% SALES TAX		
TOTAL	US DOLLARS	

PLEASE REFER TO THE PAYMENT & CREDIT CARD CHARGE AUTHORIZATION FORM

ORDERS WILL NOT BE PROCESSED WITHOUT PAYMENT

STANDARD RATE will be applied to all orders not received and paid in full by **July 16, 2026**. We reserve the right to adjust orders calculated incorrectly.

A 25% CANCELLATION FEE will be applied to all orders received and then cancelled 2 weeks prior to install. If full service has been provided then 100% of original fee will be applied.
 xpo21_rentalexhibits

CUSTOM EXHIBITS

A more sophisticated technique to exhibit marketing messages creatively and effectively!

With decades of service, Levy continues to provide viable and reliable alternatives to maximize clients' overall booth space. Our sales team and design specialists work closely with each and every client to create a unique exhibit designed to meet a wide variety of today's marketing strategies. Whether the image and budget are conservative or extravagant Levy exceeds to offer the most suitable and perfect space solutions.



Collaboratively designed to meet your specific requirements, budget, and bring your vision to reality.

Each Levy Custom Designed Exhibit will be built to exact specifications and will be:

- Unique
- Attractive
- Versatile
- Impressive
- Memorable
- Functional
- Creative
- Inviting
- Efficient

Let us help you create a one of a kind booth space.

Call our experienced professionals for an innovative, customized, and no obligation approach.



CABINETS

Straight Cabinets

All straight cabinets come with sliding doors. Optional Upgrades noted below:

- Lock for doors
- Lighting
*Jewelry Case or Show Case
- Branding - graphic panels



Cabinet "A"

1 meter cabinet with doors
39" long x 20" deep x 40" high



Cabinet "B"

1 meter Jewelry Case with doors
39" long x 20" deep x 40" high



Cabinet "C"

1 meter Show Case with doors
39" long x 20" deep x 40" high



Cabinet "D"

2 meter cabinet with doors
80" long x 20" deep x 40" high

Curved Cabinets

Optional Upgrades noted below:

- Lock for doors
- Branding - graphic panels



Cabinet "E"

1 meter curved cabinet
61" long x 20" deep x 40" high

Cabinet "F"

1 meter curved cabinet with door
61" long x 20" deep x 40" high

**Same as cabinet "E" but with door

**DISCLAIMER* Actual products and colors available may vary from the images shown. All products subject to availability*

Do you have questions?

We would be pleased to help. Contact us at: 253 437 0031

operations@levyexpo.com

www.levyexpo.com

CABINETS ORDER FORM & INVOICE

STYLE	DESCRIPTION	QTY	DISCOUNT RATE	STANDARD RATE	TOTAL
CABINET "A"	1 meter Cabinet with doors <input type="checkbox"/> Lock (\$20.00 each)		950.00	1,235.00	
	Cabinet with + custom graphic panel <input type="checkbox"/> Lock (\$20.00 each)		1,168.75	1,520.00	
CABINET "B"	1 meter Jewelry Case with doors <input type="checkbox"/> Lock (\$20.00 each) <input type="checkbox"/> Lights (\$20.00 each)		1,137.50	1,478.75	
	Jewelry Case + custom graphic panel <input type="checkbox"/> Lock (\$20.00 each) <input type="checkbox"/> Lights (\$20.00 each)		1,293.75	1,682.50	
CABINET "C"	1 meter Show Case with doors <input type="checkbox"/> Lock (\$20.00 each) <input type="checkbox"/> Lights (\$20.00 each)		1,237.50	1,608.75	
	Show Case + custom graphic panel <input type="checkbox"/> Lock (\$20.00 each) <input type="checkbox"/> Lights (\$20.00 each)		1,350.00	1,755.00	
CABINET "D"	2 meter Cabinet with doors <input type="checkbox"/> Lock (\$20.00 each)		1,225.00	1,592.50	
	2 meter Cabinet + custom graphic panel <input type="checkbox"/> Lock (\$20.00 each)		1,687.50	2,193.75	
CABINET "E"	1 meter Curved cabinet (open back)		1,112.50	1,442.50	
	Curved cabinet + custom graphic panel		1,518.75	1,975.00	
CABINET "F"	1 meter Curved cabinet with doors <input type="checkbox"/> Lock (\$20.00 each)		1,206.25	1,568.75	
	Curved cabinet w/ doors + custom graphic panel		1,637.50	2,128.75	

NOTE: Should you wish to have a graphic panel upgrade for your cabinet, please contact our Operations department to confirm details on graphic file submission.

EXHIBITOR INFORMATION	
COMPANY	
CONTACT	BOOTH#

COST SUMMARY		
RATE ADJUSTMENT	(OFFICE USE ONLY)	
CANCELLATION FEE	(OFFICE USE ONLY)	
SUBTOTAL		
2.0% CREDIT CARD FEE		
8.0% SALES TAX		
TOTAL	US DOLLARS	

PLEASE REFER TO THE PAYMENT & CREDIT CARD CHARGE AUTHORIZATION FORM
 ORDERS WILL NOT BE PROCESSED WITHOUT PAYMENT

STANDARD RATE will be applied to all orders not received and paid in full by **July 16, 2026**. We reserve the right to adjust orders calculated incorrectly.

A 25% CANCELLATION FEE will be applied to all orders received and then cancelled. If full service has been provided then 100% of original fee will be applied.

GRAPHICS AND SIGN ORDER FORM & INVOICE

STANDARD SIGN SIZES

Quantity	Description	Discount Rate	Standard Rate	Total
	7" x 11"	40.00	51.55	
	7" x 44"	47.85	61.85	
	11" x 14"	60.65	78.45	
	14" x 22"	81.15	105.65	
	22" x 28"	101.85	132.85	
	28" x 44"	145.65	189.35	

Prices listed are for one-color copy (up to 10 words) on a white background.

OPTIONAL SERVICES

Quantity	Description	Discount Rate	Standard Rate	Total
	Over 10 words (Add per word)	4.70	6.10	
	Easel back on sign (Up to 22" x 28")	6.25	8.10	
	Logo sign	Quoted on Request		
	Banner	Quoted on Request		

DIGITAL GRAPHICS (6 SQ FT MINIMUM)

- Digital files must be provided to LES specifications.
- Graphics should be sent in vector format as .eps files.
Also acceptable: Adobe Illustrator (.ai) & Corel Draw (.cdr) files
- Photographic & Pixel based complex graphics must be MINIMUM 100 dpi at actual output size.
Acceptable formats include: .tif, .bmp, & Adobe Photoshop & Corel Photo Paint files
- All text **MUST** be outlined / converted to curves, or fonts included with image files.
- Art work is to be received as file ready.
- Editing & Design time is charged at a rate of \$75.00 per hour (1 hour minimum).
- Digital files must be received at least three (3) weeks before show to receive discount price.

Quantity	Description	Discount Rate	Standard Rate	Total
	Digital Prints per sq.ft. (Mounted on Foamcore w/ Matte Laminat)	\$25.15	\$37.40	

EXHIBITOR INFORMATION

COMPANY

CONTACT

BOOTH#

INDICATE YOUR SIGN COPY HERE

ADDITIONAL SERVICES & TERMS

If you would like us to provide more information and pricing on banners, logos, silk screening, special graphics or any other items please contact our Exhibits department for a complimentary consultation.

Orders required within 72 hours before show opening may be subject to a rush delivery charge. Please allow a minimum of 24 hours for any on-site sign orders.

CHOOSE YOUR LAYOUT

 Vertical

 Horizontal

Levy Exposition Services Inc.
to design layout

Vertical

Horizontal

LETTER COLOR SELECTIONS

Blue Red Green Teal Black Purple

Black lettering will be provided unless otherwise specified.

SPECIAL INSTRUCTIONS

COST SUMMARY

RATE ADJUSTMENT	(OFFICE USE ONLY)	
100% CANCELLATION FEE	(OFFICE USE ONLY)	
SUBTOTAL		
2.0% CREDIT CARD FEE		
8.0% SALES TAX		
TOTAL	US DOLLARS	

PLEASE REFER TO THE PAYMENT & CREDIT CARD CHARGE AUTHORIZATION FORM

****ORDERS WILL NOT BE PROCESSED WITHOUT PAYMENT****

STANDARD RATE will be applied to all orders not received and paid in full by **July 16, 2026**. We reserve the right to adjust orders calculated incorrectly.

A 100% CANCELLATION FEE will be applied to all orders received then cancelled.



Fax: 253 437 0032
 14900 Interurban Avenue South, Suite 271
 Seattle, WA
 USA 98168
 Telephone: 253 437 0031
 E-mail: operations@levyexpo.com

**86th Annual Meeting of the
 Academy of Management
 July 31 - August 4, 2026
 Pennsylvania Convention Center
 Philadelphia, PA**

IN-BOOTH FORKLIFT ORDER FORM & INVOICE

TERMS & CONDITIONS

The exhibitor, his agent or representative must supply sufficient manpower including competent and authorized supervisors to manage and control the exhibit installation activity.

The exhibitor, upon signing this order form, covenants and agrees to indemnify and hold harmless Levy Exposition Services Inc., from and against all claims, demands, charges, losses or damage arising or alleged to arise directly or indirectly or incidentally by person of any act omission or operations of the exhibitor, his agent or representative, their officers, employees, agents or anyone for whom the exhibitor, his agent or representative are legally responsible. Levy Exposition Services Inc., is to be cross insured on the insurance for the exhibitor's, his agent's or representative's operations conducted at this event. Evidence of the insurance described above shall be forwarded to Levy Exposition Services Inc.

THIS SERVICE IS NOT PROVIDED BY SHOW MANAGEMENT

RATES

DESCRIPTION	STANDARD RATE
STRAIGHT TIME 8:00 AM - 4:30 PM Monday to Friday (Includes 5000 lb. Forklift and operator)	\$747.00 per Hour
STRAIGHT TIME 8:00 AM - 4:30 PM Monday to Friday (Foreman)	\$203.95 per Hour
OVERTIME 4:30 PM - 8:00 AM Monday to Friday, (Includes 5000 lb Forklift and operator) All day Saturday	\$1,017.65 per Hour
OVERTIME 4:30 PM - 8:00 AM Monday to Friday, (Foreman) All day Saturday	\$314.15 per Hour
DOUBLE TIME All day Sunday and Holidays (Includes 5000 lb Forklift and operator)	\$1,274.50 per Hour
DOUBLE TIME All day Sunday and Holidays (Foreman)	\$407.85 per Hour

ESTIMATED INSTALLATION REQUIREMENTS

DESCRIPTION	STANDARD RATE	TOTAL	There is a minimum charge of one (1) hour per forklift. Additional time thereafter is charged in one-half (½) hour increments. Date Required _____ Start Time _____
STRAIGHT TIME _____ Forklift _____ Hours	\$747.00 per Hour	\$ _____ Total	
OVERTIME _____ Forklift _____ Hours	\$1,017.65 per Hour	\$ _____ Total	
DOUBLE TIME _____ Forklift _____ Hours	\$1,274.50 per Hour	\$ _____ Total	

ESTIMATED DISMANTLE REQUIREMENTS

DESCRIPTION	STANDARD RATE	TOTAL	There is a minimum charge of one (1) hour per forklift. Additional time thereafter is charged in one-half (½) hour increments. Date Required _____ Start Time _____
STRAIGHT TIME _____ Forklift _____ Hours	\$747.00 per Hour	\$ _____ Total	
OVERTIME _____ Forklift _____ Hours	\$1,017.65 per Hour	\$ _____ Total	
DOUBLE TIME _____ Forklift _____ Hours	\$1,274.50 per Hour	\$ _____ Total	

EXHIBITOR INFORMATION

COMPANY _____

CONTACT _____

BOOTH#

COST SUMMARY

RATE ADJUSTMENT	(OFFICE USE ONLY)	
25% CANCELLATION FEE	(OFFICE USE ONLY)	
SUBTOTAL		
ADDITIONAL 25% LATE ORDER		
2.0% CREDIT CARD FEE		
TOTAL	US DOLLARS	

***PLEASE ADD 25% FOR ORDERS PLACED AFTER
 JULY 16, 2026***

PLEASE REFER TO THE PAYMENT & CREDIT CARD CHARGE AUTHORIZATION FORM

ORDERS WILL NOT BE PROCESSED WITHOUT PAYMENT

A 25% CANCELLATION FEE will be applied to all orders received then canceled. Orders cancelled within 7 days of scheduled start date will be charged 100% of the original fee.
 xpo21_in-boothforklift



Fax: 253 437 0032
 14900 Interurban Avenue South, Suite 271
 Seattle, WA
 USA 98168
 Telephone: 253 437 0031
 E-mail: operations@levyexpo.com

**86th Annual Meeting of the
 Academy of Management
 July 31 - August 4, 2026
 Pennsylvania Convention Center
 Philadelphia, PA**

SIGN & BANNER HANGING ORDER FORM & INVOICE

TERMS AND CONDITIONS

ALL OVERHEAD HANGING SIGNS **MUST** BE ASSEMBLED, INSTALLED AND DISMANTLED BY LEVY. SIGN ASSEMBLY REQUIRES A 2 PERSON CREW. THE REQUIRED AMOUNT OF MAN HOURS TO ASSEMBLE YOUR SIGN(S) WILL BE ADDED TO YOUR ACCOUNT UPON COMPLETION OF THE WORK. THERE IS A MINIMUM CHARGE OF 2 HOURS FOR INSTALL AND 2 HOURS FOR DISMANTLE FOR ALL SIGN HANGING SERVICES.
****THE SIGN ASSEMBLY LABOR ORDER FORM FOLLOWING THIS FORM MUST BE COMPLETED AND SUBMITTED WITH SIGN ASSEMBLY INSTRUCTIONS****

This order form is for labor and equipment that may be required for the hanging of signs, banners, decorations, etc. This order will be considered as a tentative reservation and **must be confirmed with a signed work order** at the Levy Exposition Services Inc. service desk.
 A sign hanging crew consists of two men and a boom lift.

SIGN & BANNER HANGING LABOR RATES

REGULAR TIME	8:00 AM - 4:30 PM Monday to Friday	Boom lift + two person crew - \$946.75 per Hour / minimum 2 hours Additional Rigger(s) - \$203.95 per Person per Hour / minimum 2 hours
OVERTIME	4:30 PM - 8:00 AM Monday to Friday, All day Saturday	Boom lift + two person crew - \$1,159.65 per Hour / minimum 2 hours Additional Rigger(s) - \$314.50 per Person per Hour / minimum 2 hours
DOUBLE TIME	All day Sunday and Holidays	Boom lift + two person crew - \$1,563.65 per Hour / minimum 2 hours Additional Rigger(s) - \$407.85 per Person per Hour / minimum 2 hours

ESTIMATED SIGN HANGING INSTALLATION REQUIREMENTS

REGULAR TIME	Laborers	Date Required	Start Time	Approx. Hours	Boom lift + two person crew - \$946.75 per Hour Additional Rigger(s) - \$203.95 per Person per Hour	\$ _____ Total
OVERTIME	Laborers	Date Required	Start Time	Approx. Hours	Boom lift + two person crew - \$1,159.65 per Hour Additional Rigger(s) - \$314.50 per Person per Hour	\$ _____ Total
DOUBLE TIME	Laborers	Date Required	Start Time	Approx. Hours	Boom lift + two person crew - \$1,563.65 per Hour Additional Rigger(s) - \$407.85 per Person per Hour	\$ _____ Total

ESTIMATED SIGN HANGING DISMANTLE REQUIREMENTS

REGULAR TIME	Laborers	Date Required	Start Time	Approx. Hours	Boom lift + two person crew - \$946.75 per Hour Additional Rigger(s) - \$203.95 per Person per Hour	\$ _____ Total
OVERTIME	Laborers	Date Required	Start Time	Approx. Hours	Boom lift + two person crew - \$1,159.65 per Hour Additional Rigger(s) - \$314.50 per Person per Hour	\$ _____ Total
DOUBLE TIME	Laborers	Date Required	Start Time	Approx. Hours	Boom lift + two person crew - \$1,563.65 per Hour Additional Rigger(s) - \$407.85 per Person per Hour	\$ _____ Total

NOTE: Any miscellaneous rigging supplies such as cable, shackles etc. required to install your sign will be calculated and added to your invoice upon completion of the installation

****PLEASE ADD 25% TO ORDERS PLACED AFTER
 JULY 16, 2026****

****All Rates are based on current wage scales and are subject to change in accordance with existing wage scales at the time of the exposition****

SPECIAL INSTRUCTIONS

EXHIBITOR INFORMATION

COMPANY _____
 CONTACT _____ **BOOTH#** _____

SUPERVISION SERVICES

(PLEASE INDICATE DESIRED SERVICE)
 EXHIBITOR SUPERVISED
 LEVY SUPERVISED (PLEASE ADD 50% FOR THIS SERVICE)

COST SUMMARY

RATE ADJUSTMENT	(OFFICE USE ONLY)	
25% CANCELLATION FEE	(OFFICE USE ONLY)	
SUBTOTAL		
SUPERVISION 50%		
ADDITIONAL 25% LATE ORDER		
2.0% CREDIT CARD FEE		
TOTAL	US DOLLARS	

PLEASE REFER TO THE PAYMENT & CREDIT CARD CHARGE AUTHORIZATION FORM

****ORDERS WILL NOT BE PROCESSED WITHOUT PAYMENT****

A 25% CANCELLATION FEE will be applied to all orders received then canceled. Orders cancelled within 7 days of scheduled start date will be charged 100% of the original fee.



Fax: 253 437 0032
 14900 Interurban Avenue South, Suite 271
 Seattle, WA
 USA 98168
 Telephone: 253 437 0031
 E-mail: operations@levyexpo.com

**86th Annual Meeting of the
 Academy of Management
 July 31 - August 4, 2026
 Pennsylvania Convention Center
 Philadelphia, PA**

SIGN ASSEMBLY LABOR ORDER FORM & INVOICE

TERMS & CONDITIONS

SIGN ASSEMBLY REQUIRES A 2 PERSON CREW. THE REQUIRED AMOUNT OF MAN HOURS TO ASSEMBLE YOUR SIGN(S) WILL BE ADDED TO YOUR ACCOUNT UPON COMPLETION OF THE WORK.

PLEASE NOTE: It is required to include sign assembly instructions when submitting your order.

****THIS SERVICE IS FOR SIGN ASSEMBLY ONLY. FOR GENERAL LABOR, PLEASE REFER TO THE LABOR ORDER FORM****

SIGN ASSEMBLY LABOR RATES

REGULAR TIME	8:00 AM - 4:30 PM Monday to Friday	\$203.95 per Person per Hour / minimum 2 hours
OVERTIME	4:30 PM - 8:00 AM Monday to Friday, All day Saturday	\$314.15 per Person per Hour / minimum 2 hours
DOUBLE TIME	All day Sunday and Holidays.	\$407.85 per Person per Hour / minimum 2 hours

****two person crew is required for sign assembly labor****

ESTIMATED INSTALLATION REQUIREMENTS

REGULAR TIME	___ Laborers	___ Hours	\$203.95 per Person per Hour	\$ _____ Total	A minimum charge for labor is two (2) hours. One (1) hour per two person crew. Labor thereafter is charged in one-half (1/2) hour increments. Date Required _____ Start Time _____
OVERTIME	___ Laborers	___ Hours	\$314.15 per Person per Hour	\$ _____ Total	
DOUBLE TIME	___ Laborers	___ Hours	\$407.85 per Person per Hour	\$ _____ Total	

ESTIMATED DISMANTLE REQUIREMENTS

REGULAR TIME	___ Laborers	___ Hours	\$203.95 per Person per Hour	\$ _____ Total	A minimum charge for labor is two (2) hours. One (1) hour per two person crew. Labor thereafter is charged in one-half (1/2) hour increments. Date Required _____ Start Time _____
OVERTIME	___ Laborers	___ Hours	\$314.15 per Person per Hour	\$ _____ Total	
DOUBLE TIME	___ Laborers	___ Hours	\$407.85 per Person per Hour	\$ _____ Total	

SUPERVISION SERVICES

(PLEASE INDICATE DESIRED SERVICE)

- EXHIBITOR SUPERVISED
- LEVY SUPERVISED (PLEASE ADD 50% FOR THIS SERVICE)

****PLEASE ADD 25% TO ORDERS PLACED AFTER
 JULY 16, 2026****

EXHIBITOR INFORMATION

COMPANY _____

CONTACT _____

BOOTH#

COST SUMMARY

RATE ADJUSTMENT	(OFFICE USE ONLY)	
CANCELLATION FEE	(OFFICE USE ONLY)	
SUBTOTAL		
SUPERVISION 50%		
ADDITIONAL 25% LATE ORDER		
2.0% CREDIT CARD FEE		
TOTAL	US DOLLARS	

PLEASE REFER TO THE PAYMENT & CREDIT CARD CHARGE AUTHORIZATION FORM

****ORDERS WILL NOT BE PROCESSED WITHOUT PAYMENT****

TERMS & CONDITIONS Gratuities in any form, including cash, gifts or labor hours for work not actually performed are prohibited. We reserve the right to adjust orders calculated incorrectly.

A 25% CANCELLATION FEE will be applied to all orders received then canceled. Orders cancelled within 7 days of scheduled start date will be charged 100% of the original fee.



Fax: 253 437 0032
 14900 Interurban Avenue South, Suite 271
 Seattle, WA
 USA 98168
 Telephone: 253 437 0031
 E-mail: operations@levyexpo.com

**86th Annual Meeting of the
 Academy of Management
 July 31 - August 4, 2026
 Pennsylvania Convention Center
 Philadelphia, PA**

LABOR ORDER FORM & INVOICE

SUPERVISION SERVICES (Please indicate desired service)

LEVY EXPOSITION SERVICES INC. SUPERVISED

MOVE IN MOVE OUT

LEVY EXPOSITION SERVICES INC. WILL SUPERVISE labor to unpack and install display before exhibitor arrival at show site and/or dismantle and pack display after show closing.

A **50% Surcharge** will be added to the labor rates below for this professional supervision.

EXHIBITOR SUPERVISED

MOVE IN MOVE OUT

EXHIBITOR WILL SUPERVISE the laborers provided by Levy Exposition Services Inc. for the installation and/or dismantle of the exhibit.

Supervisor's name _____

Starting time can be guaranteed only when labor is requested for the start of the working day at 8 AM or 30 minutes after the start of move out. For all other starting times, check in at the **Exhibitor Service Desk** one-half (1/2) hour before time requested.

LABOR RATES

REGULAR TIME	8:00 AM - 4:30 PM Monday to Friday	\$203.95 per Hour
OVERTIME	4:30 PM - 8:00AM Monday to Friday, All day Saturday	\$314.15 per Hour
DOUBLE TIME	All day Sunday and Holidays	\$407.85 per Hour

ESTIMATED INSTALLATION REQUIREMENTS

REGULAR TIME	____ Laborers	____ Hours	\$203.95 per Hour	\$_____ Total	A minimum charge for labor is one (1) hour per laborer. Labor thereafter is charged in one-half (1/2) hour increments. Date Required _____ Start Time _____
OVERTIME	____ Laborers	____ Hours	\$314.15 per Hour	\$_____ Total	
DOUBLE TIME	____ Laborers	____ Hours	\$407.85 per Hour	\$_____ Total	

ESTIMATED DISMANTLE REQUIREMENTS

REGULAR TIME	____ Laborers	____ Hours	\$203.95 per Hour	\$_____ Total	A minimum charge for labor is one (1) hour per laborer. Labor thereafter is charged in one-half (1/2) hour increments. Date Required _____ Start Time _____
OVERTIME	____ Laborers	____ Hours	\$314.15 per Hour	\$_____ Total	
DOUBLE TIME	____ Laborers	____ Hours	\$407.85 per Hour	\$_____ Total	

INBOUND FREIGHT INFORMATION ****BE SURE TO COMPLETE THE OUTBOUND FORM AS WELL****

Carrier _____ Date Shipped _____ Pro Number _____

Number of Pieces _____ Weight _____ Arrival Date (Target) _____

Loose Display Crated Display

Quantity of Ladders Required (Optional) _____

EXHIBITOR INFORMATION

COMPANY _____

CONTACT _____

BOOTH# _____

***PLEASE ADD 25% FOR ORDERS PLACED AFTER
 JULY 16, 2026***

COST SUMMARY

RATE ADJUSTMENT	(OFFICE USE ONLY)	
CANCELLATION FEE	(OFFICE USE ONLY)	
SUBTOTAL		
SUPERVISION 50%		
ADDITIONAL 25% LATE ORDER		
2.0% CREDIT CARD FEE		
TOTAL US DOLLARS		

PLEASE REFER TO THE PAYMENT & CREDIT CARD CHARGE AUTHORIZATION FORM

****ORDERS WILL NOT BE PROCESSED WITHOUT PAYMENT****

TERMS & CONDITIONS Gratuities in any form, including cash, gifts or labor hours for work not actually performed are prohibited. We reserve the right to adjust orders calculated incorrectly.

A 25% CANCELLATION FEE will be applied to all orders received then canceled. Orders cancelled within 7 days of scheduled start date will be charged 100% of the original fee.

OUTBOUND SHIPPING INSTRUCTIONS - DISMANTLE LABOR

Exhibitor Name:	Tel. #:	Booth #
Billing Address:	Fax #:	
City / State / Zip:	Auth. by:	

1 Outbound Shipping Instructions

Please complete this section if Levy will be supervising dismantle booth labor:

Exhibitor Outbound Shipping Instructions: At close of the show, exhibitor freight will be shipped to the address provided below.

If your freight is being forwarded to another show, be sure to include the name of show and your booth number

Company / Show: _____ **Booth #:** _____

Address: _____

City / State / Zip: _____

Attention: _____

Select Carrier

Ship via carrier of exhibitor's choice

Name of Carrier: _____

Ship via official show freight carrier

Select shipping method Ground

Air **Select Service Provider:** _____

Please note:

- The exhibitor is responsible for arranging either a carrier of their choice or the official show freight carrier to pick up at the close of the show.
- Levy cannot guarantee pick up time for exhibitor appointed carriers. All shipments are moved out of the exhibit hall at Levy's discretion.

Please review the Quick Facts for the Carrier Check-in time

2 Billing Information

Please indicate billing information for carrier charges if different than above.

Bill Shipping Charges to (if different from above):

Shipper (signature): _____ **Shipper (print name):** _____

Freight Charges Billed To (Company/Show): _____

Address: _____

City / State / Zip: _____

Telephone: _____ **Attention:** _____

PAYMENT & LABOR

The terms and conditions set forth below become part of the contractual agreement between Levy Exposition Services Inc. and you, the EXHIBITOR. Acceptance of said terms and conditions will be construed when any of the following conditions are met:

- ~ **WHEN THE METHOD OF PAYMENT FORM IS SIGNED; OR**
- ~ **WHEN AN ORDER FOR LABOR, SERVICES, AND/OR RENTAL EQUIPMENT IS PLACED BY AN EXHIBITOR WITH LEVY EXPOSITION SERVICES INC.; OR**
- ~ **WHEN WORK IS PERFORMED ON BEHALF OF EXHIBITOR BY LABOR SECURED THROUGH LEVY EXPOSITION SERVICES INC.**

DEFINITIONS

“Levy Exposition Services Inc.” (“LES”), and any sub-contractors affiliated within the show. The term EXHIBITOR shall be construed within the meaning of this contract as the EXHIBITOR and/or its employees, agents, representatives, and/or any Exhibitor Appointed Contractor (E.A.C.).

PAYMENT TERMS

Full payment, including any applicable tax, is due in advance or at show site. All payments must be in U.S. Funds and all checks must be drawn on a U.S. Bank. Orders received without advance payment or after the deadline date will incur additional [After Deadline] charges as indicated on each order form. All materials and equipment are on a rental basis for the duration of the show or event and remain the property of LES except where specifically identified as a sale. All LES rentals include delivery, installation and removal from EXHIBITOR's booth, unless stated otherwise. In case of cancellation, a one-hour “per person, per hour” charge will be applied to all labor, forklift and sign hanging orders that are not canceled in writing at least seven (7) days prior to the scheduled start time. If services have already been provided at the time of cancellation, 100% of original fee will be applied. It is EXHIBITOR'S responsibility to advise LES Exhibitor Services personnel of any problem with any order, and to check invoices for accuracy prior to the close of the exhibit. If EXHIBITOR is exempt from payment of sales tax, LES requires an exemption certificate for the State in which the services are to be used. Resale certificates are not valid unless EXHIBITOR is rebilling these charges to its customers. For International EXHIBITORS, LES requires 100% prepayment of advance orders, and any orders or services placed at show site must be paid at the show. For all others, should there be any pre-approved unpaid balance after the close of the show, terms will be net, due and payable in the UNITED STATES OF AMERICA, upon receipt of invoice. Effective 30 days after invoice date, any unpaid balance will bear a FINANCE CHARGE at the lesser of the maximum rate allowed by applicable law, or 1.5% per month, which is an ANNUAL PERCENTAGE RATE of 18%, and future orders will be on a pre-paid basis only. If any finance charge here under exceeds the maximum rate allowed by applicable law, the finance charge shall automatically be reduced to the maximum rate allowed, and any excess finance charge received by LES shall either be applied to reduce the principal unpaid balance or refunded to the payer. These payment terms and conditions shall be governed by and construed in accordance with the LAWS OF THE STATE OF PENNSYLVANIA. In the event of any dispute between EXHIBITOR and LES relative to any loss, damage, or claim, such EXHIBITOR shall not be entitled to and shall not withhold payment, or any partial payment, due to LES relative to any services, as an offset against the amount of any alleged loss or damage. Any claim against LES shall be considered a separate transaction, and shall be resolved on its own merits. LES reserves the right to charge EXHIBITOR for the difference between the EXHIBITOR's estimate of charges and the actual charges incurred by the EXHIBITOR, or for any charges that LES may be obligated to pay on behalf of the EXHIBITOR, including without limitation, any shipping charges.

LABOR PROVIDED UNDER THE SUPERVISION OF LES

RESPONSIBILITIES

LES shall be responsible for the performance of labor provided under this option. LES cannot assume responsibility for any acts of, or loss to, persons, parties and/or other contracting firms not under LES's direct supervision and control. In no event shall LES be liable for loss or damage caused by delay in labor beginning work when EXHIBITOR requests labor to begin later than the start of the working day. LES shall not be responsible for loss, delay or damage due to strike, lockouts, and/or work stoppages, or other causes beyond LES's reasonable control.

INDEMNIFICATION

LES agrees to indemnify, hold harmless, and defend EXHIBITOR from and against any and all demands, claims, causes of action, fines, penalties, damages, liabilities, judgments, and expenses (including but not limited to reasonable attorneys' fees and investigation costs) for bodily injury, including any injury to LES employees, or property damage arising out of work performed by labor provided by and supervised by LES, except when EXHIBITOR exercises direction and/or control over the work being performed.

LABOR PROVIDED UNDER THE SUPERVISION OF EXHIBITOR

RESPONSIBILITIES

EXHIBITOR shall be responsible for the performance of labor provided under this section. It is responsibility of EXHIBITOR to supervise labor secured through LES in a reasonable manner as to prevent bodily injury and/or property damage and also to direct them to work in a manner that is in compliance with LES Safe Work Rules and/or Federal, State, County and Local ordinances, rules and/or regulations, including but not limited to Show or Facility Management Rules and/or Regulations. It is the responsibility of EXHIBITOR to check in with the Service Desk to pick up labor, and to return to the Service Desk to release labor when the work is completed.

INDEMNIFICATION

EXHIBITOR agrees to indemnify, hold harmless, and defend LES from and against any and all demands, claims, causes of action, fines, penalties, damages, liabilities, judgements, and expenses (including but not limited to reasonable attorneys' fees and investigation costs) for bodily injury, including any injury to LES employees, and/or property damage arising out of work performed by labor provided by LES but supervised by EXHIBITOR. Further, EXHIBITOR's indemnification of LES includes any and all violations of Federal, State, County or Local ordinances, “Show Regulations and/or Rules” as published and/or set forth by Facility or Show Management, and/or directing labor provided by LES to work in a manner that violates any of the above rules, regulations, and/or ordinances.

IMPORTANT

PLEASE REFER TO LES's MATERIAL HANDLING TERMS AND CONDITIONS AS THEY RELATE TO MATERIAL HANDLING SERVICES. CONTRACTUAL TERMS DEPEND ON THE NATURE OF SERVICES SECURED BY EXHIBITOR THROUGH LES. TERMS & CONDITIONS MAY VARY FOR EACH TYPE OF SERVICE ORDERED THROUGH LES.

TERMS & CONDITIONS



SOLO RATE

ONE RATE. ONE FEE.

LEVY
EXPOSITION SERVICES INC.



THE SIMPLIFIED PRICING OF PAYING PER POUND INCLUDES:

- Receiving and unloading your materials at the advance warehouse.
- Secure storage of materials for up to 30 days before the show.
- Transfer to show-site, unload, and deliver materials to your booth.
- Removal and storage of empty containers during the show.
- Returning empties from storage at the close of the show.
- Outbound loading of your materials onto your carrier of choice or Levy's official carrier.



MATERIAL HANDLING FAQs

The following is a list of frequently asked questions pertaining to material handling and freight services. We strongly recommend that you read this document in its entirety to better familiarize yourself with the processes relating to material handling and freight services.

As the official service contractor, LEVY is the exclusive provider of freight services. Material handling includes unloading your exhibit material, storing up to 30 days in advance at the warehouse address, delivering to the booth, the handling of empty containers to and from storage, and removing of material from the booth for reloading onto outbound carriers. It should not be confused with the cost to transport your exhibit material to and from the convention or event. You have two options for shipping your advance freight — either to the warehouse or directly to show site.

HOW DO I SHIP TO THE ADVANCE WAREHOUSE?

- We will accept freight beginning 30 days prior to show move-in.
- To check on your freight arrival, call Exhibitor Services at the number listed on the Quick Facts.
- To ensure timely arrival of your materials at show site, freight should arrive by the deadline date listed on the Quick Facts and Shipping Instructions pages. Your freight will still be received after the deadline date, but additional charges will be incurred.
- The warehouse will receive shipments Monday through Friday, except holidays. Refer to the Shipping Instructions page for warehouse receiving hours.
- The warehouse will accept crates, cartons, skids, trunks/cases and carpets. Loose or pad-wrapped materials must be sent directly to show site.
- All shipments must have a bill of lading or delivery slip indicating the number of pieces, type of merchandise and weight.
- Certified weight tickets must accompany all shipments.
- Warehouse freight will be delivered to the booth prior to exhibitor setup.
- Please call the number located on the Quick Facts if you want to ship oversized material that requires special equipment to the warehouse.

HOW DO I SHIP TO SHOW SITE?

- Freight will be accepted only during exhibitor move-in. Please refer to the Quick Facts for the specific exhibitor move-in dates and times.
- All shipments must have a bill of lading or delivery slip indicating the number of pieces, type of merchandise and weight.
- Certified weight tickets must accompany all shipments.

WHAT ABOUT PREPAID OR COLLECT SHIPPING CHARGES?

- Collect shipments will be returned to the delivery carrier.
- To ensure that your freight does not arrive “collect,” mark your bill of lading “prepaid.”
- “Prepaid” designates that the transportation charges will be paid by the exhibitor or a third party.

HOW SHOULD I LABEL MY FREIGHT?

- The label should contain the exhibiting company name, the booth number and the name of the event.
- The specific shipping address for either the warehouse or show site can be found on the Quick Facts and Shipping Instructions pages.

HOW DO I ESTIMATE MY MATERIAL HANDLING CHARGES?

- Charges will be based on the weight of your shipment. Each shipment received is considered separately. The shipment weight will be multiplied by the applicable per pound rate with no round-ups. All shipments are subject to reweigh.
- On the Order Form, select whether the freight will arrive at the warehouse or be sent directly to show site.

Crated: material that is skidded or is in any type of shipping container that can be unloaded at the dock with no additional handling required.

- Add the late delivery charge listed on the Order Form if the shipment is accepted at the warehouse or at show site after the deadline date listed on the Quick Facts and Shipping Instructions pages.
- The above services, whether used completely or in part, are offered as a package and the charges will be based on the total inbound weight of the shipment.
- Shipments received without receipts or freight bills, such as UPS and Federal Express, will be delivered to the booth without guarantee of piece count or condition.

WHAT HAPPENS TO MY EMPTY CONTAINERS DURING THE SHOW?

- Pick up “Empty Labels” at the Service Center. Place a label on each container. Labeled containers will be picked up periodically and stored in non-accessible storage during the show.
- At the close of the show, the empty containers will be returned to the booth in random order. Depending on the size of the show, this process may take several hours.
- *Please note that LEVY will assume no liability for interrupted travel plans due to the length of time required for the empty container return. It is the responsibility of the exhibitor to schedule travel plans accordingly.*

HOW DO I PROTECT MY MATERIALS AFTER THEY ARE DELIVERED TO THE SHOW OR BEFORE THEY ARE PICKED UP AFTER THE SHOW?

- Consistent with trade show industry practices, there may be a lapse of time between the delivery of your shipment(s) to your booth and your arrival. The same is true for the outbound phase of the show — the time between your departure and the actual pick-up of your materials. During these times, your materials will be left unattended. We recommend that you arrange for a representative to stay with your materials or that you hire security services to safeguard your materials.

HOW DO I SHIP MY MATERIALS AFTER THE CLOSE OF THE SHOW?

- Each shipment must have a completed Material Handling Agreement in order to ship materials from the show. All pieces must be labeled individually.
- To save time, complete and submit the Outbound Shipping Form in advance, or you may contact the Service Center at show site for your shipping documents. The Material Handling Agreement and labels will be processed and available prior to show closing.
- After materials are packed, labeled, and ready to be shipped, the completed Material Handling Agreement must be turned in at the Service Center.
- Call your designated carrier with pick-up information. Please refer to the Quick Facts and Shipping Instructions pages for specific dates and times. In the event your selected carrier fails to show on final move-out day, your shipment will either be rerouted to LEVY’s carrier choice or delivered back to the warehouse at exhibitor’s expense.
- For your convenience, show-recommended carriers will be on site to handle outbound transportation.

WHERE DO I GET A FORKLIFT?

- Forklift orders to install or dismantle your booth after materials are delivered may be ordered in advance or at show site. We recommend that you order in advance to avoid additional charges at show site. Refer to the Order Form for available equipment.
- Advance and show-site orders for equipment and labor will be dispatched once a company representative signs the labor order at the Service Center.
- Start time is guaranteed only when equipment is requested for the start of the working day.

DO I NEED INSURANCE?

- Be sure your materials are insured from the time they leave your firm until they are returned after the show. It is suggested that exhibitors arrange all-risk coverage. This can be done by riders to your existing policies.
- All materials handled by LEVY are subject to the enclosed Terms and Conditions.

OTHER AVAILABLE SERVICES (may not be available in all locations)

- Cranes
- Scissor lifts, condors
- Access storage at show site
- Exhibit transportation services (see enclosed Liberty Convention Freight form)
- Security storage at show site
- Short-term and long-term warehouse storage
- Local pick-up and delivery



Fax: 253 437 0032
 14900 Interurban Avenue South, Suite 271
 Seattle, WA
 USA 98168
 Telephone: 253 437 0031
 E-mail: operations@levyexpo.com

**86th Annual Meeting of the
 Academy of Management
 July 31 - August 4, 2026
 Pennsylvania Convention Center
 Philadelphia, PA**

SOLO RATE MATERIAL HANDLING ORDER FORM & INVOICE

SOLO RATE MATERIAL HANDLING SERVICES

DUE TO LIMITED MATERIAL HANDLING SERVICES AT THE PENNSYLVANIA CONVENTION CENTER, WE HIGHLY RECOMMEND THAT ALL MATERIALS BE SHIPPED TO OUR ADVANCE WAREHOUSE IN ORDER TO AVOID POTENTIAL DELAYS IN UNLOADING AT SHOW SITE.

Material Handling Service:

Levy Exposition Services Inc. is the exclusive provider of Solo Rate Material Handling Services for the 86th Annual Meeting of the Academy of Management. Solo Rate Material Handling Services include:

- receiving and unloading your exhibit materials at the advance warehouse
- storage of exhibit materials for up to 30 days prior to the show
- transportation to show site, unloading and delivery of exhibit materials to your booth space,
- removal and storage of your empty containers during the event
- return of your empty containers at the close of the event
- outbound loading of your materials onto your carrier vehicle of choice at show site

You have the choice to ship to the advance warehouse prior to the show or to ship directly to the show site where your materials must arrive within the exhibitor move-in dates and times.

SOLO RATE MATERIAL HANDLING DESCRIPTIONS

Normal Warehouse Hours for Receiving Freight: 9:00 A.M. to 3:00 P.M. Monday through Friday, Holidays excluded.

Advance Receiving: Shipment(s) received at the Advance Warehouse *between June 30, 2026 and July 23, 2026.*

Early/Late to Warehouse & Off Target: Shipment(s) received at the Advance Warehouse *prior to June 30, 2026 or after July 23, 2026.* Shipments received at show site prior to, or after the posted exhibitor move-in day(s) / time(s).

Show Site Receiving: Shipment(s) shipped to and received at the **Pennsylvania Convention Center.** Shipments cannot be received at the **Pennsylvania Convention Center** prior to **8:00 am on Friday, July 31, 2026.**

Dedicated Delivery from Advance Warehouse: Any freight received at the Advance Warehouse after **July 23, 2026** could incur a \$650.00 delivery fee if a dedicated truck is required to deliver freight to show site.

Advance and Direct Shipment Rates	Price Per lb.
Advance Warehouse & Show Site Receiving Rate.....	\$4.25
Early/Late to Warehouse & Off Target Rate.....	\$4.85
Dedicated Delivery from Advance Warehouse (in addition to material handling rates).....	\$750.00 (flat fee)

PLEASE NOTE:

Acceptance of Terms & Conditions will be construed when the Material Handling Service Agreement is signed; or when exhibitor's materials are delivered to Levy Exposition Services Inc. warehouse or to a SHOW / EXPOSITION SITE for which Levy Exposition Services Inc. is the official show contractor.

Description	Weight in LBS	Price Per lb.	Estimated Total Charges
Advance Receiving - 1 crate, 2 boxes	298	\$4.25	\$1,266.50

EXHIBITOR INFORMATION

COMPANY

CONTACT

BOOTH#

RATE ADJUSTMENT (OFFICE USE ONLY)			
SUBTOTAL			
2.0% CREDIT CARD FEE			
TOTAL	US DOLLARS		

PLEASE REFER TO THE PAYMENT & CREDIT CARD CHARGE AUTHORIZATION FORM

****ORDERS WILL NOT BE PROCESSED WITHOUT PAYMENT****

SHIPPING INSTRUCTIONS

SHIPMENTS CAN BE SENT DIRECTLY TO THE SHOW-SITE ON MOVE-IN DAY, OR TO THE ADVANCE WAREHOUSE UP TO THIRTY DAYS PRIOR TO MOVE-IN.

All freight shipped to the advance receiving warehouse must be properly crated, boxed, or stretch wrapped on pallets.

ADVANCE RECEIVING

For advance receiving, mail or fax the Material Handling Order Form & Invoice with pre-payment to LEVY EXPOSITION SERVICES INC. Shipments sent collect **WILL NOT** be accepted.

Advance receiving includes the following:

- receiving your material at the warehouse up to thirty days in advance of the move-in day
- delivering the shipment to your booth at the facility
- removing empty crates from your booth to a designated storage area
- returning your empty crates to your booth at the close of the show
- loading your crates onto your designated carrier at the close of the show

The material handling services provided by LEVY EXPOSITION SERVICES INC. end with the close of the show. It is the responsibility of the exhibitor to make appropriate arrangements with a carrier for shipping following the close of the show. Please make special note of the allotted move-out times and days, and confirm with your carrier that they are able to meet these allotted times.

Please remove all old shipping labels and ensure that all freight destined for the advance warehouse is labeled with the following information:

86th Annual Meeting of the Academy of Management
COMPANY NAME & BOOTH #
Levy Exposition Services Inc.
c/o LibertyCFS
1618 Union Ave
Pennsauken, NJ 08110

Shipments may be sent to the advance warehouse up to thirty days prior to the move-in day for the show. All shipments however, must be received at the warehouse a minimum of one week (seven days) in advance of the show move-in date. Shipments received less than seven days prior to the move-in day are subject to extra charges and delivery time **will not** be guaranteed. All shipments must be received at the advance warehouse between the hours of 09:00 and 15:00, Monday to Friday, no earlier than **June 30, 2026** and no later than **July 23, 2026**. **Shipments that arrive prior to June 30, 2026 or after July 23, 2026 will be subject to the rate of \$4.85 per pound.**

ANY SHIPMENT(S) RECEIVED AT THE ADVANCE WAREHOUSE AFTER JULY 23, 2026 WILL INCUR A CHARGE OF \$750.00 IF A DEDICATED TRUCK IS REQUIRED TO DELIVER TO THE SHOW SITE.

Shipments must include an official weight ticket or bill of lading.

SHIPPING INSTRUCTIONS (CONT'D.)

SHOW-SITE RECEIVING

For show-site receiving, mail or fax the Material Handling Order Form & Invoice with pre-payment to LEVY EXPOSITION SERVICES INC. Shipments sent collect **WILL NOT** be accepted.

Show-site receiving includes the following:

- receiving and signing for your shipment on your behalf
- delivering the shipment to your booth at the facility
- removing empty crates from your booth to a designated storage area
- returning your empty crates to your booth at the close of the show
- loading your crates onto your designated carrier at the close of the show

The material handling services provided by LEVY EXPOSITION SERVICES INC. end with the close of the show. It is the responsibility of the exhibitor to make appropriate arrangements with a carrier for shipping following the close of the show. Please make special note of the allotted move-out times and days, and confirm with your carrier that they are able to meet these allotted times.

Please remove all old shipping labels and ensure that all freight destined for show-site receiving is labeled with the following information:

**86th Annual Meeting of the Academy of Management
COMPANY NAME & BOOTH #
Pennsylvania Convention Center
c/o Levy Exposition Services Inc.
1101 Arch Street
Philadelphia, PA 19107**

PLEASE NOTE THAT SHIPMENTS CANNOT BE RECEIVED AT THE PENNSYLVANIA CONVENTION CENTER PRIOR TO 8:00 AM ON FRIDAY, JULY 31, 2026.

ALL SHIPMENTS MUST INCLUDE A CERTIFIED WEIGHT TICKET OR BILL OF LADING. IN THE EVENT THAT YOUR SHIPMENT(S) DOES NOT INCLUDE A CERTIFIED WEIGHT TICKET, IT WILL BE WEIGHED ON-SITE AND A SURCHARGE OF \$0.25 PER POUND WILL BE APPLIED.

LIMITS OF LIABILITY

See Material Handling Terms & Conditions Sheet enclosed.

MATERIAL HANDLING

Acceptance of said terms and conditions will be constructed when any of the following conditions are met:

- ~ **THE MATERIAL HANDLING ORDER FORM AND INVOICE IS SIGNED; OR**
- ~ **WHEN EXHIBITOR'S MATERIALS ARE DELIVERED TO LES'S WAREHOUSE OR TO A SHOW/ EXPOSITION SITE FOR WHICH LEVY EXPOSITION SERVICES INC. IS THE OFFICIAL SHOW CONTRACTOR; OR**
- ~ **WHEN AN ORDER FOR LABOR AND/ OR RENTAL EQUIPMENT IS PLACED BY AN EXHIBITOR WITH LEVY EXPOSITION SERVICES INC.**

1. **DEFINITIONS.** "Levy Exposition Services Inc" ("LES"), and any sub-contractors affiliated within the show.
2. **PACKAGING AND CRATES.** LES shall not be responsible for damage to loose, uncrated materials, pad-wrapped or shrink-wrapped materials, glass breakage, concealed damage, carpets in bags or poly, or materials improperly packed. In addition, LES shall not be responsible for crates and packaging which are unsuitable for handling, in poor condition, or have prior damage. Crated and packaging should be of a design to adequately protect contents for handling by forklift and similar means.
3. **EMPTY CONTAINERS.** Empty container labels will be available at the show site service desk. Affixing labels to the containers is the sole responsibility of EXHIBITOR or his representative. All previous labels must be removed or obliterated. LES assumes no responsibility for: Error in the above procedures; Removal of containers with old empty labels & without LES labels; or Improper information on empty labels. LES WILL NOT BE LIABLE FOR LOSS OR DAMAGE TO CRATES AND CONTAINERS OR THEIR CONTENTS WHEN SAID ITEMS ARE IN EMPTY CONTAINER STORAGE.
4. **INBOUND SHIPMENT(S).** Consistent with trade show industry practices, there may be a lapse of time between the delivery of shipment(s) to the booth and the arrival of EXHIBITOR or his representative, and during such time the materials will be left unattended. LES WILL NOT BE RESPONSIBLE OR LIABLE FOR ANY LOSS, DAMAGE, THEFT, OR DISAPPEARANCE OF EXHIBITOR'S MATERIALS AFTER SAME HAVE BEEN DELIVERED TO EXHIBITOR'S BOOTH AT SHOW SITE. LES highly recommends the securing of security services for Facility or Show Management.
5. **OUTBOUND SHIPMENT(S).** Consistent with trade show industry practices, there may be a lapse of time between the completions of packing and the actual pickup of materials from the booths for loading onto a carrier and during such time the materials will be left unattended. LES WILL NOT BE RESPONSIBLE OR LIABLE FOR ANY LOSS, DAMAGE, THEFT, OR DISAPPEARANCE OF EXHIBITOR'S MATERIALS BEFORE SAME HAVE BEEN PICKED UP FOR RELOADING AT THE CONCLUSION OF THE EVENT. LES highly recommends the securing of security services from Facility or Show Management. All Material Handling Agreements submitted to LES by EXHIBITOR will be checked at the time of pickup from booth and corrections will be made where discrepancies exist between the quantities of times listed by EXHIBITOR and the actual count of such items in the booth at the time of pickup.
6. **LES'S RESPONSIBILITIES.** LES shall be responsible only for those services which it directly provides. LES assumes no responsibility for any persons, parties, or other contracting firms not under LES's direct supervision and control. LES shall not be responsible for loss, delay, or damage due to strike, lockouts, work stoppages, natural elements, vandalism, acts of God, civil disturbances, power failure, explosion, acts of terrorism or war, other causes beyond LES's reasonable control, nor for ordinary wear & tear in the handling of materials.
7. **INSURANCE.** It is understood that LES is not an insurer. Insurance on exhibit materials, if any, shall be obtained by EXHIBITOR in amounts and for perils determined by EXHIBITOR. EXHIBITOR agrees to provide LES with a release of subrogation to the extent of any insurance settlement received.
8. **CLAIM(S) FOR LOSS.** Claims for loss or damage must be reported at show-site.
 - A. **PAYMENT FOR SERVICES MAY NOT BE WITHHELD.** In the event of any dispute between the EXHIBITOR shall not be entitled to and shall not withhold payment, or any partial payment due to LES for its services, as an offset against the amount of any alleged loss or damage.
 - B. **MAXIMUM RECOVERY.** If found damaged LES's sole and exclusive MAXIMUM liability for loss or damage to EXHIBITOR's materials and EXHIBITOR's sole and exclusive remedy is limited to \$.50 per pound article with a maximum liability of \$100.00 per item, or \$1,500.00 per shipment.
9. **JURISDICTION.** THIS CONTRACT SHALL BE CONSTRUED UNDER THE LAWS OF THE STATE OF PENNSYLVANIA WITHOUT GIVING EFFECT TO ITS CONFLICT OF LAWS RULES. EXCLUSIVE VENUE FOR ALL DISPUTES ARISING OUT OF OUR RELATING TO THIS CONTRACT SHALL RESIDE IN A COURT OF COMPETENT JURISDICTION IN PHILADELPHIA, PENNSYLVANIA.
10. **INDEMNIFICATION.** EXHIBITOR agrees to indemnify, forever hold harmless and defend LES, its employees, directors, officers, and agents from and against any and all demands, claims, causes of action, fines, penalties, damages (including consequential), liability, judgments, and expenses (including but not limited to reasonable attorney's fees and investigation costs) on account of personal injury, death, or damage to or loss of property or profits arising out of, or contributed to, by any of the following:
 - EXHIBITOR's negligent supervision of any labor secured through LES, or the negligent supervision of such labor by any of EXHIBITOR's employees, agents, representative, customers, invitees and/or Exhibitor Appointed Contractor (EAC).
 - EXHIBITOR's negligence, willful misconduct, or deliberate act of EXHIBITOR's employees, agents, representatives, customers, invitees and/or any Exhibitor Appointed Contractor (EAC) at the show or exposition to which this contract relates.
 - EXHIBITOR's violation of U.S.A. or Local ordinances or the violation of Show Regulations and/or Rules as published and set forth by Facility and/or Show Management.
 - EXHIBITOR's inclusion of illegal substances, hazardous materials or waste in any shipment placed with LES and for the violation of the representations and warranties made regarding hazardous materials made on the front of this Agreement.
11. **MISCELLANEOUS.** EXHIBITOR, as a material part of the consideration LES for material handling and transportation services, waives and releases all claims against LES, its employees, agents, officers, and directors, with respect to all matters for which LES has disclaimed liability pursuant to the provisions of this contract. The EXHIBITOR acknowledges that he or she has read this agreement, understands it and agrees to be bound by its terms, and further agrees that it is the complete and exclusive agreement between the parties. The invalidity or enforceability of any provision hereof shall not affect, modify, or impair the validity and enforceability of all provisions herein.



ADVANCE WAREHOUSE

ADVANCE WAREHOUSE

TO: _____
(EXHIBITOR NAME)

TO: _____
(EXHIBITOR NAME)

BOOTH # _____

BOOTH # _____

**Levy Exposition Services Inc.
c/o LibertyCFS
1618 Union Ave
Pennsauken, NJ 08110**

**Levy Exposition Services Inc.
c/o LibertyCFS
1618 Union Ave
Pennsauken, NJ 08110**

EVENT NAME:

**86th Annual Meeting of the
Academy of Management**

EVENT NAME:

**86th Annual Meeting of the
Academy of Management**

NO. _____ # of _____ PCS.

NO. _____ # of _____ PCS.

The above labels are provided for your convenience.
Place one on each piece shipped to the ADVANCE WAREHOUSE.
If more labels are needed, copies are acceptable.



SHOW SITE

TO: _____
(EXHIBITOR NAME)

BOOTH # _____

**Pennsylvania Convention Center
c/o Levy Exposition Services Inc.
1101 Arch Street
Philadelphia, PA 19107**

EVENT NAME:

**86th Annual Meeting of the
Academy of Management**

NO. _____ # of _____ PCS.



SHOW SITE

TO: _____
(EXHIBITOR NAME)

BOOTH # _____

**Pennsylvania Convention Center
c/o Levy Exposition Services Inc.
1101 Arch Street
Philadelphia, PA 19107**

EVENT NAME:

**86th Annual Meeting of the
Academy of Management**

NO. _____ # of _____ PCS.

The above labels are provided for your convenience.
Place one on each piece shipped to the SHOW SITE.
If more labels are needed, copies are acceptable.



MOVE YOUR EXHIBIT WITH PEACE OF MIND

THE FREIGHT & CUSTOMS PARTNER YOU CAN RELY ON
FULLY DEDICATED TO YOUR CONVENTION AND TRADE SHOW SUCCESS

Putting service first and leveraging our 42 years of freight & customs experience



Transportation Services

- Ground Freight (LTL)
- Full Load
- International Freight Forwarding
- Customs Brokerage Services
- Exclusive Use Full Trailer



Customized Solutions

- Door to door service
- Catering to your specific needs
- Single point of contact
- 24/7 customer attention
- Committed to excellence

Dedicated to delivering safely and on time every time.

Call Toll Free 1-866-938-1092 or 1.905.338.3993
email: exhibitorservices@libertycfs.us - www.libertycfs.us

LAS VEGAS | TORONTO





FREIGHT & CUSTOMS ORDER FORM

1 Please accept this form as authority for LibertyCFS NV, Inc. to provide the services listed below. A second form is required for additional events.

Adobe Acrobat Reader DC may be required for completion of form. Click image to download 

Freight Only	Customs Only	Freight & Customs	Return Only
--------------	--------------	-------------------	-------------

<p>2a PICK-UP LOCATION</p> <p>Company Name _____</p> <p>Address1 _____</p> <p>Address2 _____</p> <p>City _____ State _____ ZipCode _____</p> <p>Contact _____ Phone # _____</p> <p>Email _____ IRS/Tax ID# _____</p>	<p>3 DELIVERY TO ADDRESS</p> <p>Exhibiting Company Name _____</p> <p>Show Name _____</p> <p>Address1 _____</p> <p>Address2 _____</p> <p>City _____ State _____ ZipCode _____</p> <p>Onsite Contact _____ Cell Phone # _____</p>
--	---

<p>2b SERVICES</p> <p>P/U Date _____ From _____ To _____</p> <p>Hours _____</p> <p>Dlvy Date _____ Hours _____</p> <p>Express Economy LTL 5-7 Days Int'l</p> <p>Inside Liftgate Dock</p> <p>Other _____</p>	<p>4 RETURN TO</p> <p><input type="checkbox"/> Check Box if the Return address is the same as 2a</p> <p>Consignee: _____</p> <p>Address1 _____</p> <p>Address2 _____</p> <p>City _____ State _____ ZipCode _____</p> <p>Contact _____ Phone # _____</p> <p>PU Date _____ Arrive by _____</p>
---	--

<p>5 PACKAGE INFO</p> <p>Carton(s)/Box _____</p> <p>Vinyl Case(s)/Color _____</p> <p>Wooden Crate(s) _____</p> <p>Trunk(s) / On Wheels _____</p> <p>Skid(s) - to contain # _____ of pieces</p>	<table border="1" style="width: 100%; border-collapse: collapse;"> <thead> <tr> <th style="width: 10%;">PCS</th> <th style="width: 70%;">DIMENSIONS (L x W x H)</th> <th style="width: 20%;">WGT</th> </tr> </thead> <tbody> <tr><td> </td><td> </td><td> </td></tr> <tr><td> </td><td> </td><td> </td></tr> <tr><td> </td><td> </td><td> </td></tr> <tr><td> </td><td> </td><td> </td></tr> <tr><td> </td><td> </td><td> </td></tr> <tr><td> </td><td> </td><td> </td></tr> <tr><td> </td><td> </td><td> </td></tr> <tr><td> </td><td> </td><td> </td></tr> <tr><td> </td><td> </td><td> </td></tr> <tr> <td colspan="2" style="text-align: right;">TOTAL PIECES</td> <td>TOTAL WEIGHT</td> </tr> </tbody> </table>	PCS	DIMENSIONS (L x W x H)	WGT																												TOTAL PIECES		TOTAL WEIGHT
PCS	DIMENSIONS (L x W x H)	WGT																																
TOTAL PIECES		TOTAL WEIGHT																																



6 **Declared Value - Full Value Coverage:** *The declared value will be defined as commercial value of the goods for new cargo or actual cash value or replacement value for used items plus 10%*

The following are not eligible for Full Value coverage: *Televisions/monitors, Concealed Damages and concealed shortages, Loss arising from wear, tear, gradual deterioration, depreciation, or inherent vice, Any mechanical, electrical, electronic, digital breakdown or derangement unless caused by an accident during the coverage period*

COST of COVERAGE: *Minimum Charge \$150, \$5.00 per \$100 of coverage, up to \$50,000* **VALUE COVERED**

7 **PAYMENT**

Credit Card Information / Billing Address

Credit Card Number _____ Security Code _____ Exp. Date MM / ____ / ____ YYYY

I hereby authorize the use of this card for payment of services related to this Order Form. I understand that declined credit cards are subject to a 30% surcharge.

Address _____ Signature _____

City _____ State _____ ZipCode _____

Phone _____ Email _____

Comments: Include any additional comments that will be helpful for the movement of freight and contents



2026
TRADE SHOW
KIT CATALOG

BLANC



Blanc Sofa
Bright White Leather
75"W x 35"D x 35"H



Blanc Loveseat
Bright White Leather
54"W x 35"D x 35"H



Blanc Chair
Bright White Leather
33"W x 35"D x 35"H



Blanc Bench Ottoman
Bright White Leather
48"W x 24"D x 18"H



Blanc Cube Ottoman
Bright White Leather
17"Square x 17"H

FUNCTION

Modular Seating Collection



Function Armless Chair - White
White Vinyl
28"Square x 29"H



Function Corner - White
White Vinyl
28"Square x 29"H

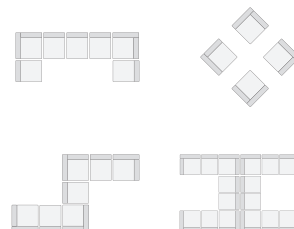

Function Armless Chair - Black
Black Vinyl
28"Square x 29"H



Function Corner - Black
Black Vinyl
28"Square x 29"H

CONTINENTAL

Modular Seating Collection



Continental Curved Loveseat

Bright White Leather
82"W x 34"D x 31"H



Continental Reverse Curved Loveseat

Bright White Leather
72"W x 34"D x 31"H



Continental Wedge Ottoman

Bright White Leather
30"W x 34"D x 19"H



Continental Curved Bench

Bright White Leather
70"W x 26"D x 19"H



Continental Half Moon Ottoman

Bright White Leather
33"W x 19"D x 19"H

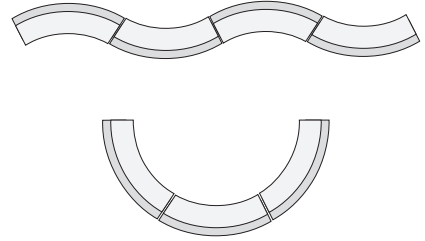

METRO



Metro Sofa

Black Leather
85"W x 35"D x 35"H



Metro Loveseat

Black Leather
60"W x 35"D x 35"H



Metro Chair

Black Leather
35"Square x 35"H

METRO



Metro Square Ottoman
Black Leather
40"Square x 17"H



Metro Bench Ottoman
Black Leather
60"W x 24"D x 17"H



Metro Cube Ottoman
Black Leather
18"Square x 18"H

GRAMMERCY

Modular Seating Collection



Grammercy Sofa
Charcoal Leather
82"W x 36"D x 36"H



Grammercy Loveseat
Charcoal Leather
57"W x 36"D x 36"H



Grammercy Chair
Charcoal Leather
28"W x 36"D x 36"H



Grammercy Corner
Charcoal Leather
36"Square x 36"H



Grammercy Square Ottoman
Charcoal Leather
40"Square x 17"H



Grammercy Bench Ottoman
Charcoal Leather
60"W x 24"D x 17"H

AUBREY



Aubrey Sofa
Light Beige Faux Linen Fabric
90"W x 35"D x 35"H



Aubrey Chair
Light Beige Faux Linen Fabric
37"W x 35"D x 35"H



Aubrey Bench Ottoman
Light Beige Faux Linen Fabric
48"W x 24"D x 18"H

LATITUDE



Latitude Sofa
Beige Olefin Fabric
91"W x 42"D x 33"H



Latitude Loveseat
Beige Olefin Fabric
91"W x 42"D x 33"H



Latitude Chair
Beige Olefin Fabric
42"W x 36"D x 33"H

VERONA



Verona Sofa
Granite Frame With Light Grey Cushions
74"W x 38"D x 25"H



Verona Chair
Granite Frame With Light Grey Cushions
28"W x 38"D x 25"H



Verona Ottoman
Granite Frame With Light Grey Cushions
26"W x 21"D x 18"H

JASPER



Jasper Sofa
Boca Bright White
64"W x 24"D x 33"H



Jasper Chair
Boca Bright White
30"W x 24"D x 33"H

NIKO



Niko Sofa
Grey Microfiber
81"W x 30"D x 38"H



Niko Loveseat
Grey Microfiber
58"W x 30"D x 38"H



Niko Chair
Grey Microfiber
31"W x 30"D x 38"H

CROMWELL



Cromwell Sofa
Royal Blue Velvet
78"W x 32"D x 29"H



Cromwell Chair
Royal Blue Velvet
32"Square x 29"H

STAGE CHAIRS



Bianca Stage Chair - Frost

Bright White Leather
26"Square x 37"H



Bianca Stage Chair - Onyx

Onyx Microfiber
26"Square x 37"H



Bianca Stage Chair - Sand

Sand Microfiber
26"Square x 37"H



Empire Chair

■ Black Leather
□ White Leather
28"W x 32"D x 32"H



Monarch Chair

Bright White Leather
28"Square x 30"H



Royce Chair - Mink

Mink Microfiber
29"W x 30"D x 33"H



Royce Chair - Oyster

Oyster Microfiber
29"W x 30"D x 33"H

OTTOMANS & BENCHES



Continental Curved Bench

Continental Bright White Leather
70"W x 26"D x 19"H



Encore Bench

Black Mango Wood
68"W x 15"D x 18"H



Square Ottoman

- Metro Black Leather
 - Grammercy Charcoal Leather
- 40"Square x 17"H



Bench Ottoman

- Metro Black Leather
 - Grammercy Charcoal Leather
- 60"W x 24"D x 17"H

BANQUETTES & TURNING BEDS



Essentials Banquette

White Leather
60"Round x 48"H (2 Pieces)



Essentials Turning Bed

White Leather
96"W x 48"D x 34"H

CUBE OTTOMANS



Rubix Cube Ottomans

- | | |
|--|--|
|  Cherry |  Lemon |
|  Cromwell |  Lime |
|  Grape |  Mango |
- 17"Square x 18"H



Blanc Cube Ottoman

Bright White Leather
17"Square x 17"H



Metro Cube Ottoman

Black Leather
18"Square x 18"H

CHARGED 



Essentials Turning Bed - Charged

White Leather
96"W x 48"D x 25"H

**White slip cover available for black charging unit.
Maximum of 1 bed per power source.



Aspen Bar Table - Charged

White/Brushed Steel
72"W x 26"D x 42"H

**Maximum of 1 table per power source.*



Aspen Cocktail Table - Charged

White/Brushed Steel
48"W x 24"D x 18"H

**Maximum of 1 table per power source.*



Patrice Table Chair - Charged

Bright White Leather
28"W x 31"D x 31"H

**Maximum of 6 daisy linked together per power source.*



Command 8' Conference Table - White Charged

96"W x 48"D x 31"H

**Maximum of 1 table per power source.*

OCCASIONAL TABLES



Aria Tables - Red
 End Table Red/Brushed Steel
 24"W x 20"D x 22"H
 Cocktail Table Red/Brushed Steel
 44"W x 20"D x 18"H



Aria Tables - Green
 End Table Green/Brushed Steel
 24"W x 20"D x 22"H
 Cocktail Table Green/Brushed Steel
 44"W x 20"D x 18"H



Aria Tables - Blue
 End Table Blue/Brushed Steel
 24"W x 20"D x 22"H
 Cocktail Table Blue/Brushed Steel
 44"W x 20"D x 18"H



Aria Tables - Purple
 End Table Purple/Brushed Steel
 24"W x 20"D x 22"H
 Cocktail Table Purple/Brushed Steel
 44"W x 20"D x 18"H



Aria Tables - White
 End Table White/Brushed Steel
 24"W x 20"D x 22"H
 Cocktail Table White/Brushed Steel
 44"W x 20"D x 18"H
 Console Table White/Brushed Steel
 44"W x 20"D x 30"H



Aria Tables - Charcoal
 End Table Storm Grey/Brushed Steel
 24"W x 20"D x 22"H
 Cocktail Table Storm Grey/Brushed Steel
 44"W x 20"D x 18"H
 Console Table Storm Grey/Brushed Steel
 44"W x 20"D x 30"H



Novel Tables
 End Table Satin Steel
 15"Square x 16"H
 Cocktail Table Satin Steel
 46"W x 15"D x 16"H



London Tables
 End Table Marble/Chrome
 24"Square x 23"H
 Cocktail Table Marble/Chrome
 40"Square x 16"H
 Console Table Marble/Chrome
 60"W x 16"D x 34"H

OCCASIONAL TABLES



Hylton Tablet Table

White/Brushed Steel
18"W x 12"D x 28"H



Gemma Accent Table - Blue Agate

Blue Agate Top/Brass Base
14"Round x 20"H



Gemma Accent Table - Citrine

Rose Quartz Top/Brass Base
14"Round x 20"H



Gemma Accent Table - Moonstone

Grey Agate Top/Brass Base
14"Round x 20"H



Gemma Accent Table - Obsidian

Obsidian Top/Brass Base
14"Round x 20"H



Brooklyn Tables

End Table Square Chrome
22"Square x 20"H
End Table Round Chrome
20"Round x 20"H
Cocktail Table Rectangle Chrome
42"W x 24"D x 16"H
Cocktail Table Round Chrome
30"Round x 16"H



Cube Tables

■ Black
□ White
Cocktail Table
24"Square x 16"H
End Table
24"Square x 21"H



Sirona Accent Table

Grey Top/Black Metal Base
18"W x 12"D x 28"H



Orbit End Table

White/Powder-Coated Aluminum
16"Round x 19"H

BARS & BAR BACKS



VIP Glow Bar 6'

Frosted Plexi With Built-in Wireless LED Kit
 72"W x 24"D x 42"H (Bar)
 13"D x 18"H (Shelf)
 Includes Remote Control



VIP Glow Bar 4'

Frosted Plexi With Built-in Wireless LED Kit
 48"W x 24"D x 42"H (Bar)
 13"D x 18"H (Shelf)
 Includes Remote Control



Agile Bar

■ Black
 □ White
 48"W x 16"D x 42"H
 2 Shelves In Back



Blox Bar Back

Walnut/Brushed Metal
 30"W x 16"D x 86"H
 Please Inquire About Shelf Dimensions



Piazza Bar Back

■ Black
 □ White
 44"W x 12"D x 79"H
 13"W x 14"H (Inside Shelf)



Elara Bar

Black Powder-Coated Steel
 Frosted Plexi With Built-in Wireless LED Kit
 72"W x 25"D x 44"H (Bar)
 Includes Remote Control



Razor Bar

Gold Powder-Coated Steel
 Frosted Plexi With Built-in Wireless LED Kit
 72"W x 25"D x 44"H (Bar)
 Includes Remote Control

STOOLS



Colin Stool
Natural Maple
20"W x 19"D x 46"H



Equino Stool
 Black
 White
 15"W x 13"D x 35"H



Clara Stool
White
17"W x 21"D x 41"H



Milo Bar Stool
 Black
 California Wine
 Chartreuse
 Chocolate
 Jade
 Victory Blue
 White
 20"W x 21"D x 41"H



Marcus Bar Stool
Steel
17"Square (at footbase) x 29"H



Caprice Stool
Black Fabric
25"W x 26"D x 44"H



Sonic Stool
Black
22"W x 23"D x 42"H

STOOLS



Nexus Stool

White
19"W x 20"D x 44"H

CAFÉ CHAIRS



Milo Chair

- Black
- California Wine
- Chartreuse
- Chocolate
- Jade
- Victory Blue
- White

20"W x 22"D x 33"H



Clara Chair

White
18"W x 21"D x 35"H



Leslie Chair

White
20"W x 23"D x 31"H



Elio Chair

Steel
17"Square x 33"H

CAFÉ CHAIRS



Caprice Chair

Black
25"W x 24"D x 32"H



Sonic Chair

Black
20"W x 21"D x 32"H



Nexus Chair

White
19"W x 22"D x 32"H



Colin Chair

Natural Maple
22"W x 19"D x 33"H

BAR TABLES



24" Square Bar Table - Sirona
 Available in Black or Chrome Base
 24"Square x 42"H



32" Round Bar Table - Cement
 Available in Black or Chrome Base
 32"Round x 42"H



32" Round Bar Table - Yukon Gold
 Available in Black or Chrome Base
 32"Round x 42"H



32" Round Bar Table - Smoke
 Available in Black or Chrome Base
 32"Round x 42"H



Euro Bar Table
 Black/Black 30"
 30"Round x 42"H
 Black/Black 36"
 36"Round x 42"H



Silk Bar Table
 Black/Chrome 30"
 30"Round x 42"H
 Black/Chrome 36"
 36"Round x 42"H



City Bar Table
 Maple/Black 30"
 30"Round x 42"H
 Maple/Black 36"
 36"Round x 42"H



Park Ave Bar Table
 Maple/Chrome 30"
 30"Round x 42"H
 Maple/Chrome 36"
 36"Round x 42"H



Summit Bar Table
 White/Black 30"
 30"Round x 42"H
 White/Black 36"
 36"Round x 42"H

BAR TABLES



Blanco Bar Table

White/Chrome 30"
30"Round x 42"H
White/Chrome 36"
36"Round x 42"H



Blanco Square Bar Table

White/Chrome
24"Square x 42"H



Blanco Rectangle Bar Table

White/Chrome
72"W x 24"D x 42"H



Spectrum Bar Table - Red

Red/Chrome
24"Square x 42"H



Spectrum Bar Table - Blue

Blue/Chrome
24"Square x 42"H



Spectrum Bar Table - Purple

Purple/Chrome
24"Square x 42"H



Spectrum Bar Table - Green

Green/Chrome
24"Square x 42"H



Aspen Bar Table

White/Brushed Steel
72"W x 26"D x 42"H

CAFÉ TABLES



24" Square Café Table - Sirona

Available in Black or Chrome Base
24"Square x 30"H



32" Round Café Table - Cement

Available in Black or Chrome Base
32"Round x 30"H



32" Round Café Table - Yukon Gold

Available in Black or Chrome Base
32"Round x 30"H



32" Round Café Table - Smoke

Available in Black or Chrome Base
32"Round x 30"H



Euro Café Table

Black/Black 30"
30"Round x 30"H
Black/Black 36"
36"Round x 30"H



Silk Café Table

Black/Chrome 30"
30"Round x 30"H
Black/Chrome 36"
36"Round x 30"H



Park Ave Café Table

Maple/Chrome 30"
30"Round x 30"H
Maple/Chrome 36"
36"Round x 30"H



City Café Table

Maple/Black 30"
30"Round x 30"H
Maple/Black 36"
36"Round x 30"H



Blanco Café Table

White/Chrome 30"
30"Round x 30"H
White/Chrome 36"
36"Round x 30"H

CAFÉ TABLES



Summit Café Table

White/Black 30"
30"Round x 30"H
White/Black 36"
36"Round x 30"H



Blanco Square Café Table

White/Chrome
24"Square x 30"H



Blanco Rectangle Café Table

White/Chrome
72"W x 24"D x 30"H



Spectrum Café Table - Red

Red/Chrome
24"Square x 30"H



Spectrum Café Table - Blue

Blue/Chrome
24"Square x 30"H



Spectrum Café Table - Purple

Purple/Chrome
24"Square x 30"H



Spectrum Café Table - Green

Green/Chrome
24"Square x 30"H



Aspen Dining Table

White/Brushed Steel
72"W x 30"D x 30"H



Encore Dining Table

Black Mango Wood
80"W x 40"D x 30"H

OFFICE SEATING



Tamiri High Back Chair

Black Leather
25"W x 27"D x 45"H



Tamiri Mid Back Chair

Black Leather
25"W x 27"D x 39"H



Tamiri Guest Chair

Black Leather
25"W x 27"D x 37"H



Accord Chair

Black
 White
 25"Square x 44"H



Worksmart Task Chair - Armless

Black
20"W x 24"D x 35"H



Worksmart Drafting Stool

Black
20"W x 24"D x 42"H (Armless)
25"W x 24"D x 42"H (With Arms)



Rimati Hi-Back Chair - White

Black
 White
 30"W x 28"D x 47-50"H



Rimati Guest Chair - Black

Black
 White
 27"W x 25"D x 40"H



Space Guest Chair

Black
26"Square x 37"H

CONFERENCE TABLES



Conference Table Round

- Espresso
 - Urban Walnut
- 42"Round x 29"H



Command 6' Conference Table

- Black
 - Sirona
 - White
- 72"W x 36"D x 31"H



Command 8' Conference Table

- Black
 - Sirona
 - White
- 96"W x 48"D x 31"H



Command 10' Conference Table

- Black
 - Sirona
 - White
- 120"W x 48"D x 31"H

OFFICE FURNITURE



Computer Kiosk

Black
 White
 24"Square x 42"H



Conference Desk

Espresso
 Urban Walnut
 Double Pedestal/Locking Drawers
 72"W x 36"D x 29"H



Jr Executive Desk

Urban Walnut
 Espresso
 Double Pedestal/Locking Drawers
 60"W x 30"D x 29"H



2-Drawer Lateral File

Urban Walnut
 Espresso
 36"W x 22"D x 29"H



Aspen Dining Table

White/Brushed Steel
 72"W x 30"D x 30"H



Brooklyn Rectangle Dining Table

Clear Glass/Chrome
 60"W x 36"D x 30"H



Brooklyn Round Dining Table

Clear Glass/Chrome
 42"Round x 30"H

METAL FILE & STORAGE CABINETS



Storage Cabinet

Black
36"W x 18"D x 72"H

PEDESTALS



42" Display Pedestals

- Black
18"Square x 42"H
- White
18"Square x 42"H
- Black
24"Square x 42"H
- White
24"Square x 42"H



36" Display Pedestals

- Black
18"Square x 36"H
- White
18"Square x 36"H
- Black
24"Square x 36"H
- White
24"Square x 36"H



30" Display Pedestals

- Black
18"Square x 30"H
- Black
18"Square x 30"H
- Black
24"Square x 30"H
- White
24"Square x 30"H



Locking Pedestal

- Black
24"Square x 42"H
- White



London Pedestal

Marble/Chrome
16"Square x 44"H

MISCELLANEOUS ITEMS



Alto Literature Rack - Black

Black/Metal
10.5"W x 9.5"D x 57"H



Alto Literature Rack - Silver

Silver/Metal
10.5"W x 9.5"D x 57"H



Compact Refrigerator

Black 4 Cubic Feet
21"W x 22"D x 32"H



2026 Specialty Furniture Order Form

Sales Representative: Operations Department

Email/Fax: operations@levyexpo.com

TRADE SHOW INFORMATION

Show Name	86th Annual Meeting of the Academy of Management	Company Name	
Show Dates	July 31 - August 4, 2026	Onsite Contact Name	
Venue Name	Pennsylvania Convention Center	Onsite Contact Cell #	
Venue Address	1101 Arch Street	Delivery Date	Time
	Philadelphia, PA 19107	Pickup Date	Time
Booth # and Name		Show Contractor	

All Furniture Subject to Availability

Terms & Conditions: **Payments:** Payment terms - 100% Payment due prior to delivery to secure the order.
Cancellation Fee: A 25% cancellation fee will be applied to all orders received and cancelled 3 weeks prior to install.
Standard Rate Surcharge: All orders received after 3 weeks prior to show date will be based on availability and a 30% surcharge will apply.

Item Number	Weight		Dimensions	Discount	Standard	Qty.	Total
Blanc (Pg. 2)							
18228-0847	100 lbs.	Blanc Bright White Leather Sofa	75"W x 35"D x 35"H	\$1,058.98	\$1,376.67		\$ -
18167-0614	90 lbs.	Blanc Bright White Leather Loveseat	54"W x 35"D x 35"H	\$1,010.68	\$1,313.88		\$ -
18284-0834	75 lbs.	Blanc Bright White Leather Chair	33"W x 35"D x 35"H	\$845.25	\$1,098.83		\$ -
18024-0072	40 lbs.	Blanc Bright White Leather Bench Ottoman	48"W x 24"D x 18"H	\$507.15	\$659.30		\$ -
18184-0274	15 lbs.	Blanc Bright White Leather Cube Ottoman	17"Square	\$177.50	\$230.75		\$ -
Function (Pg. 2)							
18284-0554	38 lbs.	Function Bright White Leather Armless Chair	28"Square x 29"H	\$540.96	\$703.25		\$ -
18066-0016	27 lbs.	Function Bright White Leather Corner	28"Square x 29"H	\$580.81	\$755.05		\$ -
18284-0452	38 lbs.	Function Black Leather Armless Chair	28"Square x 29"H	\$540.96	\$703.25		\$ -
18066-0009	27 lbs.	Function Black Leather Corner	28"Square x 29"H	\$580.81	\$755.05		\$ -
Continental (Pg. 3)							
18303-0006	105 lbs.	Continental Bright White Leather Curved Loveseat	82"W x 34"D x 31"H	\$1,044.49	\$1,357.83		\$ -
18304-0002	105 lbs.	Continental Bright White Leather Reverse Curved Loves	72"W x 34"D x 31"H	\$1,010.68	\$1,313.88		\$ -
18296-0006	35 lbs.	Continental Bright White Leather Wedge Ottoman	30"W x 34"D x 19"H	\$449.19	\$583.95		\$ -
18184-0283	75 lbs.	Continental Bright White Leather Curved Bench	70"W x 26"D x 19"H	\$530.09	\$689.12		\$ -
18184-0284	30 lbs.	Continental Bright White Leather Half Moon Ottoman	33"W x 19"D x 19"H	\$449.19	\$583.95		\$ -
Metro (Pg. 4)							
18228-0602	110 lbs.	Metro Black Leather Sofa	85"W x 35"D x 35"H	\$870.61	\$1,131.79		\$ -
18167-0467	90 lbs.	Metro Black Leather Loveseat	60"W x 35"D x 35"H	\$839.21	\$1,090.98		\$ -
18284-0482	75 lbs.	Metro Black Leather Chair	35"Square x 35"H	\$654.47	\$850.80		\$ -
18184-0179	65 lbs.	Metro Black Leather Square Ottoman	40"Square x 17"H	\$449.19	\$583.95		\$ -
18024-0008	43 lbs.	Metro Black Leather Bench Ottoman	60"W x 24"D x 17"H	\$449.19	\$583.95		\$ -
Grammercy (Pg. 4 & 5)							
18228-0605	90 lbs.	Grammercy Charcoal Leather Sofa	82"W x 36"D x 36"H	\$969.62	\$1,260.51		\$ -
18167-0469	90 lbs.	Grammercy Charcoal Leather Loveseat	57"W x 36"D x 36"H	\$845.25	\$1,098.83		\$ -
18284-0485	40 lbs.	Grammercy Charcoal Leather Chair	28"W x 36"D x 36"H	\$540.96	\$703.25		\$ -
18066-0015	51 lbs.	Grammercy Charcoal Leather Corner	36"Square x 36"H	\$621.86	\$808.42		\$ -
18184-0036	64 lbs.	Grammercy Charcoal Leather Round Ottoman	46"Round x 17"H	\$449.19	\$583.95		\$ -
18184-0033	65 lbs.	Grammercy Charcoal Leather Square Ottoman	40"Square x 17"H	\$449.19	\$583.95		\$ -
Aubrey (Pg. 5)							
18228-0891	100 lbs.	Aubrey Sofa	90"W x 35"D x 35"H	\$1,139.88	\$1,481.84		\$ -
18284-0898	75 lbs.	Aubrey Chair	37"W x 35"D x 35"H	\$717.26	\$932.43		\$ -
18184-0303	30 lbs.	Aubrey Bench Ottoman	48"W x 24"D x 18"H	\$417.80	\$543.13		\$ -
Latitude (Pg. 6)							
13229-0020	77 lbs.	Latitude Sofa	91"W x 42"D x 33"H	\$1,138.67	\$1,480.27		\$ -
13170-0011	67 lbs.	Latitude Loveseat	91"W x 42"D x 33"H	\$1,062.60	\$1,381.38		\$ -
13285-0015	37 lbs.	Latitude Chair	42"W x 36"D x 33"H	\$885.10	\$1,150.63		\$ -
Verona (Pg. 7)							
13229-0016	85 lbs.	Verona Sofa	74"W x 38"D x 25"H	\$1,248.56	\$1,623.12		\$ -
13285-0013	44 lbs.	Verona Chair	28"W x 38"D x 25"H	\$644.81	\$838.25		\$ -
13185-0010	17 lbs.	Verona Ottoman	26"W x 21"D x 18"H	\$373.12	\$485.05		\$ -
Jasper (Pg. 7)							
18228-0892	80 lbs.	Jasper Sofa	64"W x 24"D x 33"H	\$975.66	\$1,268.36		\$ -
18284-0902	60 lbs.	Jasper Chair	30"W x 24"D x 33"H	\$632.73	\$822.55		\$ -
Niko (Pg. 7)							
18228-0858	100 lbs.	Niko Sofa	81"W x 30"D x 38"H	\$1,077.09	\$1,400.22		\$ -
18167-0622	85 lbs.	Niko Loveseat	58"W x 30"D x 38"H	\$984.11	\$1,279.35		\$ -
18284-0856	70 lbs.	Niko Chair	31"W x 30"D x 38"H	\$819.89	\$1,065.86		\$ -
Cromwell (Pg. 8)							
18228-0869	100 lbs.	Cromwell Sofa	78"W x 32"D x 29"H	\$1,224.41	\$1,591.73		\$ -
18284-0873	70 lbs.	Cromwell Chair	32"W x 32"D x 29"H	\$728.12	\$946.56		\$ -
Stage Chairs (Pg. 8)							
18284-0876	35 lbs.	Bianca Stage Chair - Frost	26"Square x 37"H	\$387.61	\$503.89		\$ -
18284-0895	35 lbs.	Bianca Stage Chair - Onyx	26"Square x 37"H	\$387.61	\$503.89		\$ -
18284-0893	35 lbs.	Bianca Stage Chair - Sand	26"Square x 37"H	\$387.61	\$503.89		\$ -
18284-0621	80 lbs.	Empire Chair - Black Leather	28"W x 32"D x 32"H	\$580.81	\$755.05		\$ -
18284-0564	80 lbs.	Empire Chair - White Leather	28"W x 32"D x 32"H	\$580.81	\$755.05		\$ -
18284-0785	24 lbs.	Monarch Chair	28"Square x 30"H	\$371.91	\$483.48		\$ -
18284-0900	55 lbs.	Royce Chair - Mink	29"W x 30"D x 33"H	\$505.94	\$657.73		\$ -
18284-0901	55 lbs.	Royce Chair - Oyster	29"W x 30"D x 33"H	\$505.94	\$657.73		\$ -
Ottomans & Benches (Pg. 9)							
18184-0283	75 lbs.	Continental Bright White Leather Curved Bench	70"W x 26"D x 19"H	\$530.09	\$689.12		\$ -
05026-0012	68 lbs.	Encore Bench	68"W x 15"D x 18"H	\$480.59	\$624.76		\$ -
18184-0179	65 lbs.	Metro Black Leather Square Ottoman	40"Square x 17"H	\$449.19	\$583.95		\$ -

18184-0033	65 lbs.	Grammercy Charcoal Leather Square Ottoman	40"Square x 17"H	\$449.19	\$583.95	\$	-
18024-0008	43 lbs.	Metro Black Leather Bench	60"W x 24"D x 17"H	\$449.19	\$583.95	\$	-
18024-0002	43 lbs.	Grammercy Charcoal Leather Bench	60"W x 24"D x 17"H	\$449.19	\$583.95	\$	-
Banquettes & Turning Beds (Pg. 9)							
18011-0011	185 lbs.	Essentials White Leather Banquette (2 pcs)	60"Round x 48"H	\$1,314.97	\$1,709.46	\$	-
02082-0033	200 lbs.	Essentials White Leather Turning Bed	96"W x 48"D x 34"H	\$1,580.62	\$2,054.80	\$	-
Cube Ottomans (Pg. 10)							
18184-0294	10 lbs.	Rubix Cube - Cherry	17"Square x 18"H	\$182.33	\$237.03	\$	-
18184-0295	10 lbs.	Rubix Cube - Cromwell	17"Square x 18"H	\$182.33	\$237.03	\$	-
18184-0296	10 lbs.	Rubix Cube - Grape	17"Square x 18"H	\$182.33	\$237.03	\$	-
18184-0293	10 lbs.	Rubix Cube - Lemon	17"Square x 18"H	\$182.33	\$237.03	\$	-
18184-0297	10 lbs.	Rubix Cube - Lime	17"Square x 18"H	\$182.33	\$237.03	\$	-
18184-0298	10 lbs.	Rubix Cube - Mango	17"Square x 18"H	\$182.33	\$237.03	\$	-
18184-0274	15 lbs	Blanc Bright White Leather Cube	17"Square x 17"H	\$177.50	\$230.75	\$	-
18184-0128	15 lbs.	Metro Black Leather Cube Ottoman	18"Square x 18"H	\$177.50	\$230.75	\$	-
Charged (Pg. 11)							
22100-0001	192 lbs.	Essentials Turning Bed w/Charging Station Insert	96"W x 48"D x 19"H	\$1,753.29	\$2,279.28	\$	-
22001-0001	80 lbs.	Aspen Bar Table - Charged	72"W x 26"D x 42"H	\$1,026.38	\$1,334.29	\$	-
22002-0002	55 lbs.	Aspen Cocktail Table - Charged	48"W x 24"D x 18"H	\$580.81	\$755.05	\$	-
18284-0861	52 lbs.	Patrice Tablet Chair	28"W x 30.5"D x 31"H	\$639.98	\$831.97	\$	-
14062-0307	125 lbs.	Command White 8' Conference Table - Charged	96"W x 48"D x 31"H	\$1,451.42	\$1,886.84	\$	-
Occasional Tables (Pg. 12 & 13)							
12108-0001-12304-0006	10 lbs.	Aria Red End Table	24"W x 20"D x 22"H	\$316.37	\$411.27	\$	-
12049-0001-12050-0004	20 lbs.	Aria Red Cocktail Table	44"W x 20"D x 18"H	\$333.27	\$433.25	\$	-
12108-0001-12304-0005	10 lbs.	Aria Green End Table	24"W x 20"D x 22"H	\$316.37	\$411.27	\$	-
12049-0001-12050-0007	20 lbs.	Aria Green Cocktail Table	44"W x 20"D x 18"H	\$333.27	\$433.25	\$	-
12108-0001-12304-0004	10 lbs.	Aria Blue End Table	24"W x 20"D x 22"H	\$316.37	\$411.27	\$	-
12049-0001-12050-0005	20 lbs.	Aria Blue Cocktail Table	44"W x 20"D x 18"H	\$333.27	\$433.25	\$	-
12108-0001-12304-0007	10 lbs.	Aria Purple End Table	24"W x 20"D x 22"H	\$316.37	\$411.27	\$	-
12049-0001-12050-0006	20 lbs.	Aria Purple Cocktail Table	44"W x 20"D x 18"H	\$333.27	\$433.25	\$	-
12108-0001-12304-0002	10 lbs.	Aria White End Table	24"W x 20"D x 22"H	\$316.37	\$411.27	\$	-
12231-0001-12305-0002	35 lbs.	Aria White Console Table	44"W x 20"D x 30"H	\$350.18	\$455.23	\$	-
12049-0001-12050-0003	20 lbs.	Aria White Cocktail Table	44"W x 20"D x 18"H	\$333.27	\$433.25	\$	-
12108-0001-12304-0001	10 lbs.	Aria Charcoal End Table	24"W x 20"D x 22"H	\$316.37	\$411.27	\$	-
12231-0001-12305-0001	35 lbs.	Aria Charcoal Console Table	44"W x 20"D x 30"H	\$350.18	\$455.23	\$	-
12049-0001-12050-0002	20 lbs.	Aria Charcoal Cocktail Table	44"W x 20"D x 18"H	\$333.27	\$433.25	\$	-
18024-0010	30 lbs.	Novel End Table	15"Square x 16"H	\$398.48	\$518.02	\$	-
18024-0011	50 lbs.	Novel Cocktail Table	46"W x 15"D x 16"H	\$449.19	\$583.95	\$	-
12107-0493	27 lbs.	London End Table	24"Square x 23"H	\$341.72	\$444.24	\$	-
12230-0110	49 lbs.	London Console Table	60"W x 16"D x 34"H	\$415.38	\$539.99	\$	-
12055-0428	55 lbs.	London Cocktail Table	40"Square x 16"H	\$383.99	\$499.18	\$	-
12107-0467	13 lbs.	Hylton Tablet Table	18"W x 12"D x 28"H	\$283.76	\$368.89	\$	-
12003-0117	27 lbs.	Gemma Accent Table - Blue Agate	14"Round x 20"H	\$350.18	\$455.23	\$	-
12003-0115	27 lbs.	Gemma Accent Table - Citrine	14"Round x 20"H	\$350.18	\$455.23	\$	-
12003-0116	27 lbs.	Gemma Accent Table - Moonstone	14"Round x 20"H	\$350.18	\$455.23	\$	-
12003-0120	27 lbs.	Gemma Accent Table - Obsidian	14"Round x 20"H	\$350.18	\$455.23	\$	-
12107-0494	21 lbs.	Brooklyn II Square End Table	22"W X 22"D X 20"H	\$292.22	\$379.88	\$	-
12107-0495	15 lbs.	Brooklyn II Round End Table	20"Round X 20"H	\$292.22	\$379.88	\$	-
12055-0429	35 lbs.	Brooklyn II Rect Cocktail Table	42"W X 24"D X 16"H	\$324.82	\$422.26	\$	-
12055-0430	25 lbs.	Brooklyn II Round Cocktail Table	30"Round X 16"H	\$324.82	\$422.26	\$	-
12055-0285	40 lbs.	24" Cube Cocktail Table - Black	24"Square x 16"H	\$316.37	\$411.27	\$	-
12055-0286	40 lbs.	24" Cube Cocktail Table - White	24"Square x 16"H	\$316.37	\$411.27	\$	-
12107-0296	50 lbs.	24" Cube End Table - Black	24"Square x 21"H	\$324.82	\$422.26	\$	-
12107-0297	55 lbs.	24" Cube End Table - White	24"Square x 21"H	\$324.82	\$422.26	\$	-
12003-0102	17 lbs.	Sirona Accent Table	18"W x 12"D x 28"H	\$283.76	\$368.89	\$	-
13110-0017	10 lbs.	Orbit End Table	16"Round x 19"H	\$236.67	\$307.67	\$	-
Bars & Bar Backs (Pg. 14)							
05012-0076	185 lbs.	VIP Glow Bar 6'	72"W x 24"D x 42"H	\$1,150.75	\$1,495.97	\$	-
05012-0075	130 lbs.	VIP Glow Bar 4'	48"W x 24"D x 42"H	\$969.62	\$1,260.51	\$	-
05012-0053	70 lbs.	Black Bar - 2 Shelf	48"W x 16"D x 42"H	\$530.09	\$689.12	\$	-
05012-0054	70 lbs.	White Bar - 2 Shelf	48"W x 16"D x 42"H	\$530.09	\$689.12	\$	-
12112-0010	60 lbs.	Blox Bar Back	30"W x 16"D x 86"H	\$662.92	\$861.79	\$	-
05001-0017	150 lbs.	Piazza Bar Back - Black	44"W x 12"D x 80"H	\$621.86	\$808.42	\$	-
05001-0018	150 lbs.	Piazza Bar Back - White	44"W x 12"D x 80"H	\$621.86	\$808.42	\$	-
05012-0083	282 lbs.	Elara Bar	72"W x 25"D x 44"H	\$1,762.95	\$2,291.84	\$	-
05012-0082	220 lbs.	Razor Bar	72"W x 25"D x 44"H	\$1,762.95	\$2,291.84	\$	-
Bar Stools (Pg. 15 & 16)							
05237-0305	17 lbs.	Colin Stool	20"W x 19"D x 46"H	\$249.95	\$324.94	\$	-
05237-0306-05033-0001-05034-0001	27 lbs.	Milo Bar Stool - Black	20"W x 21"D x 41"H	\$283.76	\$368.89	\$	-
05237-0306-05033-0007-05034-0001	27 lbs.	Milo Bar Stool - California Wine	20"W x 21"D x 41"H	\$283.76	\$368.89	\$	-
05237-0306-05033-0005-05034-0001	27 lbs.	Milo Bar Stool - Chartreuse	20"W x 21"D x 41"H	\$283.76	\$368.89	\$	-
05237-0306-05033-0013-05034-0001	27 lbs.	Milo Bar Stool - Chocolate	20"W x 21"D x 41"H	\$283.76	\$368.89	\$	-
05237-0306-05033-0011-05034-0001	27 lbs.	Milo Bar Stool - Jade	20"W x 21"D x 41"H	\$283.76	\$368.89	\$	-
05237-0306-05033-0009-05034-0001	27 lbs.	Milo Bar Stool - Victory Blue	20"W x 21"D x 41"H	\$283.76	\$368.89	\$	-
05237-0306-05033-0002-05034-0001	27 lbs.	Milo Bar Stool - White	20"W x 21"D x 41"H	\$283.76	\$368.89	\$	-
05237-0160	35 lbs.	Equino Bar Stool - Black	15"W x 13"D x 35"H	\$309.12	\$401.86	\$	-
05237-0041	35 lbs.	Equino Bar Stool - White	15"W x 13"D x 35"H	\$309.12	\$401.86	\$	-
05237-0298	16 lbs.	Clara Stool	17"W x 21"D x 41"H	\$298.25	\$387.73	\$	-
05237-0215	15 lbs.	Marcus Stool	18"Square x 29"H	\$225.80	\$293.54	\$	-
05237-0169	25 lbs.	Caprice Stool	25"W x 26"D x 44"H	\$309.12	\$401.86	\$	-
05237-0042	15 lbs.	Sonic Stool	22"W x 23"D x 42"H	\$249.95	\$324.94	\$	-
05237-0300	6 lbs.	Nexus Stool	19"W x 20"D x 44"H	\$258.41	\$335.93	\$	-
Café Chairs (Pg. 16 & 17)							
05035-0053-05033-0003-05034-0001	19 lbs.	Milo Chair - Black	20"W x 22"D x 33"H	\$175.09	\$227.61	\$	-
05035-0053-05033-0008-05034-0001	19 lbs.	Milo Chair - California Wine	20"W x 22"D x 33"H	\$175.09	\$227.61	\$	-

05035-0053-05033-0006-05034-00	19 lbs.	Milo Chair - Chartreuse	20"W x 22"D x 33"H	\$175.09	\$227.61	\$	-
05035-0053-05033-0014-05034-00	19 lbs.	Milo Chair - Chocolate	20"W x 22"D x 33"H	\$175.09	\$227.61	\$	-
05035-0053-05033-0012-05034-00	19 lbs.	Milo Chair - Jade	20"W x 22"D x 33"H	\$175.09	\$227.61	\$	-
05035-0053-05033-0010-05034-00	19 lbs.	Milo Chair - Victory Blue	20"W x 22"D x 33"H	\$175.09	\$227.61	\$	-
05035-0053-05033-0004-05034-00	19 lbs.	Milo Chair - White	20"W x 22"D x 33"H	\$175.09	\$227.61	\$	-
05035-0051	11 lbs.	Clara Chair	18"W x 21"D x 35"H	\$199.24	\$259.01	\$	-
05035-0008	10 lbs.	Lestlie Chair	17"W x 21"D x 31"H	\$159.39	\$207.21	\$	-
05035-0023	24 lbs.	Elio Chair	17"Square x 33"H	\$177.50	\$230.75	\$	-
14233-0025	20 lbs.	Caprice Chair - Black	25"W x 24"D x 32"H	\$177.50	\$230.75	\$	-
14233-0016	10 lbs.	Sonic Chair	20"W x 21"D x 32"H	\$177.50	\$230.75	\$	-
05035-0050	5 lbs.	Nexus Chair	19"W x 22"D x 32"H	\$211.31	\$274.71	\$	-
05035-0052	12 lbs.	Colin Chair	22"W x 19"D x 33"H	\$177.50	\$230.75	\$	-
Bar Tables (Pg. 18, 19 & 20)							
05246-0003-05036-0050	27 lbs.	24" Square Bar Table - Cosmo/Chrome Base	24"Square x 42"H	\$333.27	\$433.25	\$	-
05246-0018-05036-0050	31 lbs.	24" Square Bar Table - Cosmo/Black Base	24"Square x 42"H	\$333.27	\$433.25	\$	-
05246-0003-05036-0051	27 lbs.	24" Square Bar Table - Emerald Tide/Chrome Base	24"Square x 42"H	\$333.27	\$433.25	\$	-
05246-0018-05036-0051	31 lbs.	24" Square Bar Table - Emerald Tide/Black Base	24"Square x 42"H	\$333.27	\$433.25	\$	-
05246-0003-05036-0049	27 lbs.	24" Square Bar Table - Icebreaker/Chrome Base	24"Square x 42"H	\$333.27	\$433.25	\$	-
05246-0018-05036-0049	31 lbs.	24" Square Bar Table - Icebreaker/Black Base	24"Square x 42"H	\$333.27	\$433.25	\$	-
05246-0003-05036-0048	27 lbs.	24" Square Bar Table - Sirona/Chrome Base	24"Square x 42"H	\$333.27	\$433.25	\$	-
05246-0018-05036-0048	31 lbs.	24" Square Bar Table - Sirona/Black Base	24"Square x 42"H	\$333.27	\$433.25	\$	-
05246-0003-05036-0046	27 lbs.	32" Round Bar Table - Cement/Chrome Base	32"Round x 42"H	\$449.19	\$583.95	\$	-
05246-0018-05036-0046	31 lbs.	32" Round Bar Table - Cement/Black Base	32"Round x 42"H	\$449.19	\$583.95	\$	-
05246-0003-05036-0047	27 lbs.	32" Round Bar Table - Yukon Oak/Chrome Base	32"Round x 42"H	\$449.19	\$583.95	\$	-
05246-0018-05036-0047	31 lbs.	32" Round Bar Table - Yukon Oak/Black Base	32"Round x 42"H	\$449.19	\$583.95	\$	-
05036-0053-05246-0018	33 lbs.	32" Round Bar Table - Smoke/Black Base	32"Round x 42"H	\$449.19	\$583.95	\$	-
05036-0053-05246-0003	38 lbs.	32" Round Bar Table - Smoke/Chrome Base	32"Round x 42"H	\$449.19	\$583.95	\$	-
05246-0018-05036-0001	34 lbs.	Euro Bar Table Black/Black 30" Round	30"Round x 42"H	\$316.37	\$411.27	\$	-
05246-0018-05036-0004	41 lbs.	Euro Bar Table Black/Black 36" Round	36"Round x 42"H	\$324.82	\$422.26	\$	-
05246-0003-05036-0001	30 lbs.	Silk Bar Table Black/Chrome 30" Round	30"Round x 42"H	\$316.37	\$411.27	\$	-
05246-0003-05036-0004	37 lbs.	Silk Bar Table Black/Chrome 36" Round	36"Round x 42"H	\$324.82	\$422.26	\$	-
05246-0018-05036-0037	34 lbs.	City Bar Table Maple/Black 30" Round	30"Round x 42"H	\$316.37	\$411.27	\$	-
05246-0018-05036-0038	41 lbs.	City Bar Table Maple/Black 36" Round	36"Round x 42"H	\$324.82	\$422.26	\$	-
05246-0003-05036-0037	30 lbs.	Park Ave Bar Table Maple/Chrome 30" Round	30"Round x 42"H	\$316.37	\$411.27	\$	-
05246-0003-05036-0038	37 lbs.	Park Ave Bar Table Maple/Chrome 36" Round	36"Round x 42"H	\$324.82	\$422.26	\$	-
05246-0018-05036-0003	34 lbs.	Summit Bar Table White/Black 30" Round	30"Round x 42"H	\$316.37	\$411.27	\$	-
05246-0018-05036-0006	41 lbs.	Summit Bar Table White/Black 36" Round	36"Round x 42"H	\$324.82	\$422.26	\$	-
05246-0003-05036-0003	30 lbs.	Blanco Bar Table White/Chrome 30" Round	30"Round x 42"H	\$316.37	\$411.27	\$	-
05246-0003-05036-0006	37 lbs.	Blanco Bar Table White/Chrome 36" Round	36"Round x 42"H	\$324.82	\$422.26	\$	-
05246-0003-05036-0008	28 lbs.	Blanco Bar Table - White/Chrome 24"Square	24"Square x 42"H	\$316.37	\$411.27	\$	-
05246-0003-05036-0009	69 lbs.	Blanco Rectangle Bar Table - White/Chrome	72"W x 24"D x 42"H	\$490.25	\$637.32	\$	-
05246-0003-05036-0033	28 lbs.	Spectrum Bar Table - Red	24"Square x 42"H	\$341.72	\$444.24	\$	-
05246-0003-05036-0034	28 lbs.	Spectrum Bar Table - Blue	24"Square x 42"H	\$341.72	\$444.24	\$	-
05246-0003-05036-0035	28 lbs.	Spectrum Bar Table - Purple	24"Square x 42"H	\$341.72	\$444.24	\$	-
05246-0003-05036-0036	28 lbs.	Spectrum Bar Table - Green	24"Square x 42"H	\$341.72	\$444.24	\$	-
05204-0001	75 lbs.	Aspen Bar Table	72"W x 26"D x 42"H	\$877.85	\$1,141.21	\$	-
Café Tables (Pg. 20, 21 & 22)							
05246-0002-05036-0050	24 lbs.	24" Square Cafe Table - Cosmo/Chrome Base	24"Square x 30"H	\$333.27	\$433.25	\$	-
05246-0017-05036-0050	27 lbs.	24" Square Cafe Table - Cosmo/Black Base	24"Square x 30"H	\$333.27	\$433.25	\$	-
05246-0002-05036-0051	24 lbs.	24" Square Cafe Table - Emerald Tide/Chrome Base	24"Square x 30"H	\$333.27	\$433.25	\$	-
05246-0017-05036-0051	27 lbs.	24" Square Cafe Table - Emerald Tide/Black Base	24"Square x 30"H	\$333.27	\$433.25	\$	-
05246-0002-05036-0049	24 lbs.	24" Square Cafe Table - Icebreaker/Chrome Base	24"Square x 30"H	\$333.27	\$433.25	\$	-
05246-0017-05036-0049	27 lbs.	24" Square Cafe Table - Icebreaker/Black Base	24"Square x 30"H	\$333.27	\$433.25	\$	-
05246-0002-05036-0048	24 lbs.	24" Square Cafe Table - Sirona/Chrome Base	24"Square x 30"H	\$333.27	\$433.25	\$	-
05246-0017-05036-0048	27 lbs.	24" Square Cafe Table - Sirona/Black Base	24"Square x 30"H	\$333.27	\$433.25	\$	-
05246-0002-05036-0046	24 lbs.	32" Round Café Table - Cement/Chrome Base	32"Round x 30"H	\$449.19	\$583.95	\$	-
05246-0017-05036-0046	27 lbs.	32" Round Café Table - Cement/Black Base	32"Round x 30"H	\$449.19	\$583.95	\$	-
05246-0002-05036-0047	24 lbs.	32" Round Café Table - Yukon Oak/Chrome Base	32"Round x 30"H	\$449.19	\$583.95	\$	-
05246-0017-05036-0047	27 lbs.	32" Round Café Table - Yukon Oak/Black Base	32"Round x 30"H	\$449.19	\$583.95	\$	-
05246-0002-05036-0053	38 lbs.	32" Round Café Table - Smoke/Chrome Base	32"Round x 30"H	\$449.19	\$583.95	\$	-
05246-0017-05036-0053	35 lbs.	32" Round Café Table - Smoke/Black Base	32"Round x 30"H	\$449.19	\$583.95	\$	-
05246-0017-05036-0001	30 lbs.	Euro Café Table Black/Black 30" Round	30"Round x 30"H	\$316.37	\$411.27	\$	-
05246-0017-05036-0004	37 lbs.	Euro Café Table Black/Black 36" Round	36"Round x 30"H	\$324.82	\$422.26	\$	-
05246-0002-05036-0001	27 lbs.	Silk Café Table Black/Chrome 30" Round	30"Round x 30"H	\$316.37	\$411.27	\$	-
05246-0002-05036-0004	34 lbs.	Silk Café Table Black/Chrome 36" Round	36"Round x 30"H	\$324.82	\$422.26	\$	-
05246-0002-05036-0037	27 lbs.	Park Ave Café Table Maple/Chrome 30" Round	30"Round x 30"H	\$316.37	\$411.27	\$	-
05246-0002-05036-0038	34 lbs.	Park Ave Café Table Maple/Chrome 36" Round	36"Round x 30"H	\$324.82	\$422.26	\$	-
05246-0017-05036-0037	30 lbs.	City Café Table Maple/Black 30" Round	30"Round x 30"H	\$316.37	\$411.27	\$	-
05246-0017-05036-0038	37 lbs.	City Café Table Maple/Black 36" Round	36"Round x 30"H	\$324.82	\$422.26	\$	-
05246-0002-05036-0003	27 lbs.	Blanco Café Table White/Chrome 30" Round	30"Round x 30"H	\$316.37	\$411.27	\$	-
05246-0002-05036-0006	34 lbs.	Blanco Café Table White/Chrome 36" Round	36"Round x 30"H	\$324.82	\$422.26	\$	-
05246-0017-05036-0003	30 lbs.	Summit Café Table White/Black 30" Round	30"Round x 30"H	\$316.37	\$411.27	\$	-
05246-0017-05036-0006	37 lbs.	Summit Café Table White/Black 36" Round	36"Round x 30"H	\$324.82	\$422.26	\$	-
05246-0002-05036-0008	25 lbs.	Blanco Café Table White/Chrome 24"Square	24"Square x 30"H	\$316.37	\$411.27	\$	-
05246-0002-05036-0009	63 lbs.	Blanco Café Table White/Chrome Rectangle	72"W x 24"D x 30"H	\$490.25	\$637.32	\$	-
05246-0002-05036-0033	25 lbs.	Spectrum Café Table - Red	24"Square x 29"H	\$341.72	\$444.24	\$	-
05246-0002-05036-0034	25 lbs.	Spectrum Café Table - Blue	24"Square x 29"H	\$341.72	\$444.24	\$	-
05246-0002-05036-0035	25 lbs.	Spectrum Café Table - Purple	24"Square x 29"H	\$341.72	\$444.24	\$	-
05246-0002-05036-0036	25 lbs.	Spectrum Café Table - Green	24"Square x 29"H	\$341.72	\$444.24	\$	-
05090-0001	90 lbs.	Aspen Dining Table	72"W x 30"D x 30"H	\$753.48	\$979.52	\$	-
05088-0531	193 lbs.	Encore Dining Table	80"W x 40"D x 30"H	\$886.31	\$1,152.20	\$	-
Office Seating (Pg. 23)							
14136-0002	38 lbs.	Tamiri High Back Chair	25"W x 27"D x 45"H	\$398.48	\$518.02	\$	-
14176-0007	37 lbs.	Tamiri Mid Back Chair	27"Square x 39"H	\$350.18	\$455.23	\$	-
14128-0002	41 lbs.	Tamiri Guest Chair	25"W x 26"D x 37"H	\$324.82	\$422.26	\$	-

14136-0081	40 lbs.	Accord High Back Chair - Black	25"Square x 44"H	\$497.49	\$646.74	\$	-
14136-0010	40 lbs.	Accord High Back Chair - White	25"Square x 44"H	\$497.49	\$646.74	\$	-
14250-0055	35 lbs.	Worksmart Task Chair - Armless	20"W x 24"D x 35"H	\$244.91	\$318.39	\$	-
14307-0011	40 lbs.	Worksmart Drafting Stool - Armless	21"W x 24"D x 48"H	\$266.81	\$346.85	\$	-
14307-0012	40 lbs.	Worksmart Drafting Stool With Arms	25"W x 24"D x 48"H	\$283.76	\$368.89	\$	-
14136-0105	40 lbs.	Rimati Hi-Back Chair - Black	30"W x 28"D x 47-50"H	\$379.50	\$493.35	\$	-
14136-0106	40 lbs.	Rimati Hi-Back Chair - White	30"W x 28"D x 47-50"H	\$379.50	\$493.35	\$	-
14128-0122	34 lbs.	Rimati Guest Chair - Black	27"W x 25"D x 40"H	\$240.35	\$312.46	\$	-
14128-0123	34 lbs.	Rimati Guest Chair - White	27"W x 25"D x 40"H	\$240.35	\$312.46	\$	-
14128-0028	25 lbs.	Space Guest Chair - Black	26"Square x 37"H	\$278.36	\$361.86	\$	-
Conference Tables (Pg. 24)							
14062-0105	97 lbs.	42" Round Conference Table - Black	42" Round x 29"H	\$440.74	\$572.96	\$	-
14062-0106	97 lbs.	42" Round Conference Table - Mahogany	42" Round x 29"H	\$440.74	\$572.96	\$	-
14062-0297	90 lbs.	Command Conference Table - 6' Black	72"W x 36"D x 31"H	\$786.08	\$1,021.91	\$	-
14062-0303	90 lbs.	Command Conference Table - 6' Sirona	72"W x 36"D x 31"H	\$786.08	\$1,021.91	\$	-
14062-0300	90 lbs.	Command Conference Table - 6' White	72"W x 36"D x 31"H	\$786.08	\$1,021.91	\$	-
14062-0298	125 lbs.	Command Conference Table - 8' Black	96"W x 48"D x 31"H	\$845.25	\$1,098.83	\$	-
14062-0304	125 lbs.	Command Conference Table - 8' Sirona	96"W x 48"D x 31"H	\$845.25	\$1,098.83	\$	-
14062-0301	125 lbs.	Command Conference Table - 8' White	96"W x 48"D x 31"H	\$845.25	\$1,098.83	\$	-
14062-0299	182 lbs.	Command Conference Table - 10' Black	120"W x 48"D x 31"H	\$969.62	\$1,260.51	\$	-
14062-0305	182 lbs.	Command Conference Table - 10' Sirona	120"W x 48"D x 31"H	\$969.62	\$1,260.51	\$	-
14062-0302	182 lbs.	Command Conference Table - 10' White	120"W x 48"D x 31"H	\$969.62	\$1,260.51	\$	-
Office Furniture (Pg. 24 & 25)							
14309-0001	125 lbs.	Computer Kiosk - Black	24"Square x 42"H	\$647.22	\$841.39	\$	-
14179-0005	125 lbs.	Computer Kiosk - White	24"Square x 42"H	\$647.22	\$841.39	\$	-
SHELL14083-0279,BBF14189-0044	314 lbs.	Conference Desk - Espresso	72"W x 36"D x 29"H	\$934.40	\$1,214.71	\$	-
SHELL14083-0344,BBF14189-0100	314 lbs.	Conference Desk - Urban Walnut	72"W x 36"D x 29"H	\$1,001.39	\$1,301.80	\$	-
14083-0105	280 lbs.	Jr Executive Desk - Espresso	60"W x 30"D x 29"H	\$772.80	\$1,004.64	\$	-
14083-0106	280 lbs.	Jr Executive Desk - Urban Walnut	60"W x 30"D x 29"H	\$894.70	\$1,163.11	\$	-
14143-0135	150 lbs.	2 Drawer Lateral File - Espresso	36"W x 22"D x 29"H	\$462.00	\$600.60	\$	-
14143-0163	150 lbs.	2 Drawer Lateral File - Urban Walnut	36"W x 22"D x 29"H	\$545.16	\$708.71	\$	-
05088-0498	77 lbs.	Brooklyn II Rect Dining Table	60"W x 36"D x 30"H	\$647.22	\$841.39	\$	-
05088-0499	59 lbs.	Brooklyn II Round Dining Table	42" Round x 30"H	\$507.15	\$659.30	\$	-
05090-0001	90 lbs.	Aspen Dining Table	72"W x 30"D x 30"H	\$753.48	\$979.52	\$	-
Metal File & Storage Cabinets (Pg. 26)							
14034-0015	135 lbs.	Storage Cabinet - Black	36"W x 18"D x 72"H	\$357.42	\$464.65	\$	-
Pedestals (Pg. 27)							
12091-0023	55 lbs.	Display Pedestal 18" x 42" Black	18"Square x 42"H	\$563.50	\$732.55	\$	-
12091-0004	55 lbs.	Display Pedestal 18" x 42" White	18"Square x 42"H	\$563.50	\$732.55	\$	-
12091-0002	120 lbs.	Display Pedestal 24" x 42" Black	24"Square x 42"H	\$524.40	\$681.72	\$	-
12091-0030	120 lbs.	Display Pedestal 24" x 42" White	24"Square x 42"H	\$524.40	\$681.72	\$	-
12091-0024	50 lbs.	Display Pedestal 18" x 36" Black	18"Square x 42"H	\$481.85	\$626.41	\$	-
12091-0034	50 lbs.	Display Pedestal 18" x 36" White	18"Square x 36"H	\$481.85	\$626.41	\$	-
12091-0031	75 lbs.	Display Pedestal 24" x 36" Black	24"Square x 36"H	\$563.50	\$732.55	\$	-
12091-0033	75 lbs.	Display Pedestal 24" x 36" White	24"Square x 36"H	\$563.50	\$732.55	\$	-
12091-0025	45 lbs.	Display Pedestal 18" x 30" Black	18"Square x 30"H	\$364.55	\$473.92	\$	-
12091-0003	45 lbs.	Display Pedestal 18" x 30" White	18"Square x 30"H	\$364.55	\$473.92	\$	-
12091-0001	80 lbs.	Display Pedestal 24" x 30" Black	24"Square x 30"H	\$499.10	\$648.83	\$	-
12091-0032	80 lbs.	Display Pedestal 24" x 30" White	24"Square x 30"H	\$499.10	\$648.83	\$	-
14309-0001	125 lbs.	Locking Pedestal Black	24"Square x 42"H	\$647.22	\$841.39	\$	-
14179-0005	125 lbs.	Locking Pedestal White	24"Square x 42"H	\$647.22	\$841.39	\$	-
12091-0043	24 lbs.	London Pedestal	16"Square x 44"H	\$357.42	\$464.65	\$	-
Miscellaneous Items (Pg. 28)							
14308-0005	7 lbs.	Alto Literature Rack - Black	10.5"W x 9.5"D x 57"H	\$249.95	\$324.94	\$	-
14308-XXXX	7 lbs.	Alto Literature Rack - Silver	10.5"W x 9.5"D x 57"H	\$249.95	\$324.94	\$	-
01209-0003	50 lbs.	Compact Refrigerator Black - 4.0 Cu Ft	21"W x 22"D x 32"H	\$449.19	\$583.95	\$	-



DO NOT MAIL ORDER FORM - Email / Fax Form ONLY

Please make payments payable to: Levy Exposition Services, Inc.
 271 - 14900 Interurban Avenue S.
 Seattle, WA 96168

Total Product	\$	-
Late Fee %	\$	-
Sub Total	\$	-
Credit Card Fee %	2.0%	\$ -
Sales Tax %	8.0%	\$ -
Total Amount Due	\$	-

Company Name	-				
Street Address					
City					
State					
Zip Code					
Name / Date of Show		Signature			
Booth Number	-		Date		
Contact Name		Email Address			
Contact Cell		Fax #			
Special Instructions:					



Phone: 301-459-9011
E-Mail: exhibits@projection.com

Save 10% by Ordering Online!

For online ordering, AOM 2026 exhibitors will receive an email from Projection including your username and temporary password. You may then follow the link below to order.

projection.boomerecommerce.com/home

Advance Rate Deadline: 7/6/2026

As the official A/V, computer, and data display supplier, Projection will be on-site from set-up through dismantle. When on-site, please visit our service desk with questions.

Company Name: _____

Booth #: _____ On-Site Contact: _____

Ordered By: _____ On-Site Contact Cell Phone: _____

E-Mail Address: _____ On-Site Contact E-Mail: _____

Delivery Date: _____ Delivery Time: 8-10am 10am-12pm 1-3pm 3-5pm

A representative of your company **MUST BE PRESENT** at the time of delivery for set-up instructions and delivery verification. Please note that equipment will not be left in an unattended booth. **Power, and Internet if needed, must be ordered separately through the official supplier listed in the exhibitor kit.**

Flat Panel Displays & Accessories					
(1920x1080 Resolution, Internal Speakers)					
	Qty	Advance Rate through 7/6/26	Standard Rate	Total	
32" HD LED Please Indicate: <input type="checkbox"/> Table Top Stand <input type="checkbox"/> Wall Mount <input type="checkbox"/> Floor Stand		\$550.00	\$660.00		
43" HD LED Please Indicate: <input type="checkbox"/> Table Top Stand <input type="checkbox"/> Wall Mount <input type="checkbox"/> Floor Stand		\$825.00	\$990.00		
49" HD LED Please Indicate: <input type="checkbox"/> Wall Mount <input type="checkbox"/> Floor Stand		\$1,056.00	\$1,320.00		
55" HD LED Please Indicate: <input type="checkbox"/> Wall Mount <input type="checkbox"/> Floor Stand		\$1,188.00	\$1,485.00		
65" HD LED Please Indicate: <input type="checkbox"/> Wall Mount <input type="checkbox"/> Floor Stand		\$1,584.00	\$1,980.00		
Media Player		\$85.00	\$100.00		
Shelf to be Attached to Floor Stand		\$51.00	\$67.00		
Computer Only Flat Panel Displays					
(1920x1080 Resolution, No Internal Sound)					
	Qty			Total	
23" LCD Please Indicate: <input type="checkbox"/> Table Top Stand <input type="checkbox"/> Wall Mount		\$460.00	\$575.00		
Computers & Accessories					
	Qty			Total	
CALL for small format Desktop or Mac pricing					
Laptop: Windows 10/Office 2019, USB-C, HDMI 2.0, Anti-Virus, Wifi, Mouse & Cable Lock		\$495.00	\$575.00		
Wireless PC Remote Control		\$45.00	\$55.00		
Wireless PC Keyboard		\$45.00	\$55.00		
Wireless PC Mouse		\$45.00	\$55.00		

*Rates published are for the entire length of the event.

Audio Equipment				
	Qty	Advance Rate through 7/6/26	Standard Rate	Total
Wireless UHF Mic Kit Please Indicate: <input type="checkbox"/> Lavalier <input type="checkbox"/> Handheld		\$395.00	\$495.00	
Small Exhibit Booth Sound System Includes: 1 Speaker / Mixer / 1 Wired Handheld Microphone Please Indicate: <input type="checkbox"/> Ground <input type="checkbox"/> Floor Stand <input type="checkbox"/> Wall Mount		\$440.00	\$550.00	
Large Exhibit Booth Sound System Includes: 2 Speakers / Mixer / 1 Wired Handheld Microphone Please Indicate: <input type="checkbox"/> Ground <input type="checkbox"/> Floor Stand <input type="checkbox"/> Wall Mount		\$570.00	\$715.00	



Value Add Specialty Items

Please call 301-459-9011 for Equipment and Labor quotes.

LED Video Walls

Stand out from the other booths on the show floor by presenting your message on a video wall.

Key Features:

- Configure to fit your budget and booth
- Higher resolutions and superior brightness



Additional Screen Options

Projection can offer various screen sizes and resolutions for your booth. *Screen Options:*

- LCD & LED: 70" - 90"
- Touch Screens: 24" - 80"
- 4K UHD Monitors: 49" - 98"



*Rates published are for the entire length of the event.

Totals		
1) EQUIPMENT TOTAL	1)	
2) Shipping & Handling - 20% of line 1	2)	
3) Equipment Set-Up & Dismantle - 25% of line 1, or \$225.00, whichever is greater	3)	
4) Optional Damage Waiver* - 3% of line 1	4)	
5) ORDER SUB TOTAL	5)	
6) Sales Tax - 8% of line 5	6)	
7) TOTAL DUE	7)	

*Covers damage to equipment while on show site. Lost or stolen equipment is not covered.

Payment Information	
Company Name: _____ Cardholder Name: _____ Billing Address: _____ City, State, Zip: _____	<div style="border: 1px solid black; padding: 5px;"> Method of Payment: <input type="checkbox"/> American Express <input type="checkbox"/> MasterCard <input type="checkbox"/> Visa <input type="checkbox"/> Check (US Only) <input type="checkbox"/> Wire Transfer </div> Card Number: <input style="width: 150px; height: 20px;" type="text"/> Expiration Date: _____ Security Code: _____
Please include any special notes or instructions pertaining to your exhibit order here:	<div style="border: 1px solid black; height: 80px;"></div>

Remit To	
	Projection 5803 Rolling Road, Suite 200 Springfield, VA 22152 E-mail To: exhibits@projection.com
Projection	

For additional equipment needs and pricing please call (301) 459-9011

****Please read and sign the Rental Agreement terms on the bottom of page 4.****

86TH ANNUAL MEETING



ACADEMY OF Management

31 JULY-4 AUGUST | PHILADELPHIA, PA, USA



Phone: 301-459-9011

E-Mail: exhibits@projection.com

Save 10% by Ordering Online!

For online ordering, AOM 2026 exhibitors will receive an email from Projection including your username and temporary password. You may then follow the link below to order.

projection.boomerecommerce.com/home

Advance Rate Deadline: 7/6/2026

As the official A/V, computer, and data display supplier, Projection will be on-site from set-up through dismantle. When on-site, please visit our service desk with questions.

Company Name:

RENTAL AGREEMENT

All equipment rentals are based on Event Rates and apply to event days only. Rental prices do not include labor, delivery, electrical services, or removal of equipment from your booth. It is understood and agreed that EXHIBITOR is renting PROJECTION PRESENTATION TECHNOLOGY equipment for a specified period of time and is responsible for its safe return. EXHIBITOR hereby agrees to use all rental equipment with reasonable care to prevent excessive wear and tear and/or damage to said property. All rental equipment must be returned to PROJECTION PRESENTATION TECHNOLOGY in the same condition as it was in at the time of delivery to EXHIBITOR, reasonable wear and tear excluded. EXHIBITOR will immediately notify PROJECTION PRESENTATION TECHNOLOGY of any damage to the rental equipment, and EXHIBITOR hereby agrees to be billed for any damage to, or loss of, rental equipment damaged while in EXHIBITOR'S care, custody and/or control. In no event shall EXHIBITOR permit any equipment to be used and/or possessed by other exhibiting parties other than the named EXHIBITOR without prior consent of PROJECTION PRESENTATION TECHNOLOGY in each instance.

CANCELLATION

Cancellation of equipment rental and services must be received **72 hours prior** to delivery date to avoid a 33% charge on equipment. If equipment and services have already been set up and delivered at the time of cancellation, labor and equipment will be charged in full.

PLEASE NOTE: ALL PAYMENT, INCLUDING APPLICABLE TAX, IS DUE AT THE TIME SERVICES ARE ORDERED. PURCHASE ORDERS ARE NOT CONSIDERED PAYMENT.

PAYMENT TERMS

Full payment, including any applicable tax, is due at the time services are ordered. All payments must be in U.S. dollars. Orders received without advance payment or after the deadline date 7/6/26 will incur additional charges as indicated on the order form. All materials and equipment are on a rental basis for the duration of the event and remain the property of PROJECTION PRESENTATION TECHNOLOGY except where specifically identified as a sale. It is the EXHIBITOR'S responsibility to advise our Exhibit Service Personnel of any problem with any order, and to check invoices for accuracy prior to the close of the exhibit. If you are exempt from payment of sales tax, PROJECTION PRESENTATION TECHNOLOGY requires you to forward an exemption certificate for the state in which the services are to be used. Resale certificate are not valid unless EXHIBITOR is re-billing these charges to its customers. For International exhibitors, PROJECTION PRESENTATION TECHNOLOGY requires 100% prepayment of advance orders, and any orders or services placed at show site must be paid at the show.

These payment terms and conditions shall be governed by and construed in accordance with the LAWS OF THE STATE OF VA. In the event of any dispute between the EXHIBITOR and PROJECTION PRESENTATION TECHNOLOGY relative to any loss, damage, or claim, such EXHIBITOR shall not be entitled to and shall not withhold payment, or any partial payment, due to PROJECTION PRESENTATION TECHNOLOGY for its services, as an offset against the amount of any alleged loss or damage. Any claims against PROJECTION PRESENTATION TECHNOLOGY shall be considered a separate transaction, and shall be resolved on its own merits. PROJECTION PRESENTATION TECHNOLOGY reserves the right to charge EXHIBITOR for the difference between the EXHIBITOR'S estimate of charges and the actual charges incurred by EXHIBITOR, or for any charges that PROJECTION PRESENTATION TECHNOLOGY may be obligated to pay on behalf of EXHIBITOR, including without limitation, any shipping charges.

UNPAID BALANCES

Should there be any pre-approved unpaid balance after the close of the event, terms will be net, due and payable in Springfield, VA upon receipt of invoice. Effective 30 days after invoice date, any unpaid balance will bear a FINANCE CHARGE at the lesser of the maximum rate allowed by applicable law, or 1.5% per month, which is an ANNUAL PERCENTAGE RATE of 18%, and future orders will be on a prepayment basis only. If any finance charge hereunder exceeds the maximum rate allowed by applicable law, the finance charge shall automatically be reduced to the maximum rate allowed, and any excess finance charge received by PROJECTION PRESENTATION TECHNOLOGY shall be either applied to reduce the principal unpaid balance or refunded to the payer.

AGREEMENT

Yes, I have read the terms and conditions specified above and I agree to authorize this transaction.

Company Name:

Booth Number:

Purchaser Name:

Date:

ELECTRIC SERVICE & LABOR INSTALLATION ORDER FORM

(PLEASE READ TERMS AND CONDITIONS ATTACHED)

IF PAYING BY CHECK RETURN THIS FORM TO:

PCCA/LEGENDS Order
 Processing 1101 Arch Street
 Philadelphia, PA 19107
 Inquiries only: 215-418-4815
 Email: exhibitorservices@paconvention.com

ORDERS MAY BE PLACED ONLINE AT: www.paconvention.com

ACADEMY OF MANAGEMENT

**ADVANCED DEADLINE DATE:
 JULY 7, 2026**

Exhibiting Firm: _____ Booth No.: _____
 Billing Address: _____ Event: _____
 City: _____ State: _____ Zip: _____
 Exhibitor Contact Name: _____ Title: _____
 Phone: _____ E-Mail: _____

CREDIT CARD AUTHORIZATION REQUIRED for advance order, on-site charges, labor, and materials.

In our efforts to follow PCI compliance security guidelines and to safeguard your credit card information, we can no longer accept credit card information via this order form. Complete and email form to: exhibitorservices@paconvention.com Once processed a payment link will be sent to the email address provided above.

STANDARD 110V/120V SERVICE				
Service originates back center of inline & peninsula booths				
QTY	SERVICE	ADVANCED RATE	STANDARD RATE	TOTAL
	500 watts	\$140.00	\$168.00	
	1000 watts	\$175.00	\$205.00	
	2000 watts	\$225.00	\$270.00	
	24 hr. – 500 watts	\$210.00	\$252.00	
	24 hr. – 1000 watts	\$232.00	\$325.00	
	24 hr. – 2000 watts	\$292.00	\$395.00	
	OTHER	Call for Pricing		

RENTAL LIGHTS				
Price includes power, labor to install/dismantle and a one-time focus on stage				
QTY	SERVICE	ADVANCED RATE	STANDARD RATE	TOTAL
	4' Track w/ 3 - 90w Lamps	\$167.00	\$263.00	
	8' Track w/ 3 - 90w Lamps	\$232.00	\$315.00	
	Each additional track lamp	\$20.00	\$30.00	
	LED Clamp Stem Light	\$130.00	\$175.00	
	Parcan Overhead Light	\$670.00	\$900.00	

208V MOTORS/MACHINERY SERVICE				
Labor and material charges will apply				
QTY	SERVICE	ADVANCED RATE	STANDARD RATE	TOTAL
	20 amp 1Phase	\$410.00	\$510.00	
	30 amp 1Phase	\$430.00	\$575.00	
	60 amp 3Phase	\$800.00	\$1,120.00	
	100 amp 3Phase	\$1,280.00	\$1,500.00	
	24HR 20amp 1Phase	\$615.00	\$765.00	
	24HR 30amp 1Phase	\$645.00	\$862.50	
	24HR 60amp 3Phase	\$1,200.00	\$1,680.00	
	24HR 100amp 3Phase	\$1,920.00	\$2,250.00	
	OTHER	Call for Pricing		

- Installation/Dismantle labor is scheduled and billed at rates in accordance with show move-in/out.
- The minimum charge of ½ hour installation will apply.
- Dismantle floor labor will be automatically charged 50% of the total installation hours.
- Dismantle of overhead services, signs, truss, motors and lights will be billed on actual labor hours incurred.

ELECTRICAL LABOR RATES PER HOUR

STRAIGHT TIME: WEEKDAYS 8 AM – 4:30 PM		OVER TIME: WEEKDAYS 6 AM TO 8 AM AND AFTER 4:30 PM: ALL DAY SATURDAY		DOUBLE TIME: ALL DAY SUNDAY AND HOLIDAYS	
Regular Rate	\$146.00	Regular Rate	\$219.00	Regular Rate	\$292.00

Unsupervised Installation Supervised Installation by Exhibitor/Name: _____ Cell: _____
 NO YES EAC or I&D Company: _____ On-Site POC: _____ Cell: _____

PLEASE CHECK ALL WORK REQUIRED BELOW. Only PCC/LEGENDS Global electricians under IBEW Jurisdiction perform the electrical installations listed below. Material charges will apply where applicable, i.e. extension cords/feed cables/cord caps, lift charges, etc.

<input type="checkbox"/> Distribution of cords/cables under carpet/flooring from point of origin	<input type="checkbox"/> 208v/480v Service Connection Electrical Equipment/Hardwire	<input type="checkbox"/> Dedicated Daily Booth Labor (submit schedule if necessary)	<input type="checkbox"/> Close Circuit TV, Security Cameras/Monitors Satellite Dish Assembly / Dismantle & Cabling
<input type="checkbox"/> Network Data Cabling Distribution & Terminations	Date: _____ Time: _____	Date: _____ Time: _____	Date: _____ Time: _____
Date: _____ Time: _____	<input type="checkbox"/> PCC/LEGENDS Truss/Motors/Lights	<input type="checkbox"/> Suspended Electrical Signs w/Lights and/or Motors	<input type="checkbox"/> Disconnect/Connect Vehicle Battery
<input type="checkbox"/> Booth Lighting, Stem Lights & Electrical Signage	<input type="checkbox"/> Exhibitor Rental	Install Date: _____	Disconnect Date: _____
Install Date: _____	Install Date: _____	Time: _____	Time: _____
Time: _____	Time: _____	Dismantle Date: _____	Reconnect Date: _____
Dismantle Date: _____	Dismantle Date: _____		

TERMS & CONDITIONS

1. INSTRUCTION FOR COMPLETING ORDER FORM

- A. Order must be typed or clearly printed; illegible forms will delay processing.
- B. Services requested at location other than back of booth must include proper forms and diagrams.
- C. For services and equipment not listed on the service order form, call the PCCA/LEGENDS Global Exhibitor Services Department for availability and quotes at **(215) 418-2190** or e-mail **exhibitorservices@paconvention.com**

2. PAYMENT TERMS & CONDITIONS

- A. **Full payment is due along with service order.** Credit Card Pre-authorization for onsite charges, labor and materials is required when placing an order.
Acceptable forms of payment are:
 - Company check (drawn on a U.S. bank) payable to **Pennsylvania Convention Center Authority, (PCCA)**
 - Accepted credit cards: VISA / MASTERCARD / AMERICAN EXPRESS.Service orders will not be processed without payment. Exhibiting firms with outstanding balances from prior events must submit payments, otherwise services will not be provided. To pay by credit card, please contact our **Accounts Receivable Department** at **215-418-4794** for assistance.
- B. **Advanced Rates** will be applicable to service orders received with payment in full by the deadline date noted on the front of this form.
- C. **Standard Rates** will be applicable to service orders received after the Advanced Rate Deadline or orders received without payment.
- D. **Third party billing** is available upon request. Please contact the **PCCA/Legends Global Finance Department** at **215-418-4794** for approval.
- E. **Outstanding balance** for services will be automatically billed to the credit card on file.
- F. Credit will not be given for service installed and not used.
- G. **Cancellation of services** must be received by PCC/Legends Global Exhibitor Services Department 21 days prior to the event. Services cancelled without 21 days prior written notice is subject to a cancellation fee of 25%.
- H. A \$25.00 handling charge will be assessed for returned checks due to insufficient funds.
- I. Rates are based on current wages and are subject to change without notice.
- J. **Claims** regarding services provided by PCCA/Legends Global will not be considered unless filed by customer issued prior to the close of show.
- K. **Refunds** of overpayments and dispute resolutions will be issued by submitting requests to PCCA/Legends Global Finance Department within 30 days of the close of final invoice.
- L. For unpaid balances on **pre-approved** invoices, terms will be net, due and payable upon receipt of invoice. Effective 30 days after invoice date, any unpaid balances will bear a **FINANCE CHARGE** at the lower of the maximum rate allowed by law, or 1.5% per month by law. The finance charge shall automatically be reduced to the maximum rate allowed. Any excess finance charge received by the PCCA/Legends Global shall be applied to reduce the principal unpaid balance or refunded to the payer. This payment Terms & Conditions agreement shall be governed by and construed in accordance with the laws of the Commonwealth of Pennsylvania.
- M. **International exhibitors** are required to make 100% pre-payment for services. Payment may be made by check in U.S. funds drawn on a U.S. bank or by approved credit card.
- N. For companies exempt from sales tax, PCCA/LEGENDS Global requires an exemption certificate for the Commonwealth of Pennsylvania. Resale certificates are not valid unless we have re-billing charges to customers.

3. EXPLANATION OF SERVICE

- A. Rates shown for services are for the duration of event and include installation to exhibitor booth in the most convenient manner, in most cases to the back center of an in-line booth or perimeter of island and peninsula booths. All services originate from the floor unless otherwise noted or requested.
- B. Advance orders will be installed based on the schedule determined by the General Service Contractor and/or Show Management. On-site orders will be processed in the order that they are received at the PCC Exhibitor Services Desk.
- C. Electrical services will be turned off one hour after the close of show each day and restored one hour prior to opening.
- D. 24-hour electrical service is available for refrigeration, electronics, and circulation pumps.

4. RULES & REGULATIONS FOR SERVICES

- A. Services provided may not be shared by multiple exhibits.
- B. All materials and equipment furnished by PCC and/or its sub-contractors shall remain the property of PCC and/or its Sub-contractors.
- C. All rental equipment furnished by PCC not left in the booth at the close of the show will be charged an additional 75% of the original rental equipment charge.
- D. PCC and/or its sub-contractors are authorized to cut floor coverings to gain access to utility floor ports and permit the installation of service.
- E. PCC or its sub-contractors are not responsible for interruption or fluctuation of services.
- F. All equipment provided by customers shall be compliant with the National and Philadelphia Electrical and Building Codes and PCCA/Legends Global safety standards. All equipment is subject to inspection and approval by PCC prior to connection to service.
- G. Customer is responsible for any lost or damaged equipment supplied by the PCC.



ANNOUNCING OUR NEW LIGHTING PRODUCTS AVAILABLE FOR RENTAL

What attracts visitors to your booth? Excellent exhibit design and a marketing strategy. We think the most important aspect of the marketing strategy is the lighting. To help draw visitors and business to your booth we are pleased to offer two new lighting products available for rental: Skanda LED Clamp on Light, the Nora Track Light and PARCAN Overhead Light. The clamp on lights are useful if you are trying to create smaller spotlights on specific posters, the track lights are useful if you are trying to highlight specific products within your booth and our PARCAN Overhead Light is useful if you want to add additional overhead lighting to your booth or spotlight a hanging sign, etc.

With these ideas in mind, we think you'll be better able to market your product or service and attract attention!

RENTAL PRICE INCLUDES POWER, INSTALLATION/DISMANTLE AND A ONE-TIME FOCUS



Light attracts people, it shows the way, and when we see it in the distance, we follow it. Ricardo Legorreta - architect

PCC Electrical Safety Standards For Exhibit Booths



Pennsylvania
Convention Center
PHILADELPHIA

AN  MANAGED FACILITY

All exhibitors must use hard or extra hard cords as per National Electrical Code Standards. Cords must be UL listed, 12 AWG, and grounded. Exhibitors can run the cord along the drape line of their booth. An electrician is needed to distribute the power under the floor or to a certain location other than the drape line. Any cords that are smaller than 12 gauge or ungrounded along with ramps or cord coverings of any sort are prohibited within the booth.

Cords are available to rent through our Exhibitor Services Department.



Any/all wiring that may need to be spliced onsite must be done by a PCC electrician. These connections must also be in a box per the National Electrical Codes standards.



All track lights **must** have a capped end. An Opened-ended track is considered a live wire and a hazard, especially when attached to metal booth pipe & drape. All lighting fixtures must be UL listed and listed/labeled for its intended use as per National Electrical Code standards.

Caps are available for purchase through our Exhibitor Services Department.

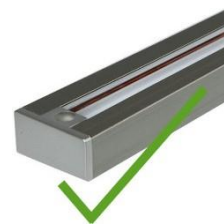

Separately derived power systems are **PROHIBITED** to be used in the building.





Electrical Service Checklist

- ✓ Electrical service is not included with the rental of your booth space or meeting room.
- ✓ Each electrical drop within the booth must be a minimum of 500 watts. This is for the protection of the equipment getting plugged in, the safety of the people in the booth (exhibitors and attendees), and to prevent over-current interruption during the show.
- ✓ Electrical service will be turned off one hour after the close of show and restored one hour prior to show opening each day. *24HR service is available upon request for perishables, refrigeration, electronics, pumps, etc. at an additional cost.*
- ✓ Exhibitors are **NOT PERMITTED** to run cords under carpet.
- ✓ Exhibitors are permitted to run cords along the drape line **ONLY**.
- ✓ All exhibitor extension cords must be grounded 3-wire 12-gauge UL listed approved cords. (household un-grounded cords are NOT permitted)
- ✓ All equipment provided by the exhibitor shall be UL listed and approved. Equipment must be compliant with the National Electrical Code, Philadelphia Building Codes, Fire Marshal, and PCCA/ASM Global safety standards.
- ✓ Exhibits found to be non-compliant will receive notification and be expected to correct the infraction. If not corrected, additional charges may be incurred.
- ✓ In all booths where an Exhibitor Appointed Contractor (EAC) or decorator is utilized, ASM Global Electricians must install all light fixtures, lit signage, hardwiring, and all other work deemed as electrical jurisdiction.
- ✓ Vehicle batteries shall be disconnected and reconnected by ASM Global Electricians per the Philadelphia Fire Marshal.
- ✓ All electrical equipment and installations are subject to inspection. Any installed equipment found presenting a hazard will be subject to removal or the exhibitor will be responsible for any charges incurred due to corrections.
- ✓ Electrical Distribution panels in the back of booths **MUST** remain accessible at all times. Exhibitors are **PROHIBITED** from accessing panels and PCCA electrical connections.
- ✓ Labor calls for PCCA/ASM Global electricians must be selected as "Under Supervision" or "Without Supervision" and noted as such on the Electrical Labor Order form. **"Will Calls" are not acceptable.**
- ✓ It is recommended that you supply the Utilities Department with a rendering and scaled floor plan noting power drop locations in your booth and/or meeting room.
- ✓ All on-site orders for electric service and electric labor will be billed at Standard/Show Site Rates and could lead to delays in your booth build.
- ✓ Separately derived electrical systems are **NOT PERMITTED** to be used in the building.

Updated 10/14/2019

WIRED INTERNET SERVICE ORDER FORM

(PLEASE READ TERMS AND CONDITIONS ATTACHED)

IF PAYING BY CHECK RETURN THIS FORM TO:

PCCA/LEGENDS Order Processing
1101 Arch Street
Philadelphia, PA 19107
Inquiries only: 215-418-2190
Email: exhibitorservices@paconvention.com

ACADEMY OF MANAGEMENT

**ADVANCED DEADLINE
DATE: JULY 7, 2026**

ORDERS MAY BE PLACED ONLINE AT: www.paconvention.com

Exhibiting Firm: _____ Booth No.: _____
 Billing Address: _____ Event: _____
 City: _____ State: _____ Zip: _____
 Exhibitor Contact Name: _____ Title: _____
 Phone: _____ E-Mail: _____

CREDIT CARD AUTHORIZATION REQUIRED for advance order, on-site charges, labor, and materials.

In our efforts to follow PCI compliance security guidelines and to safeguard your credit card information, we can no longer accept credit card information via this order form. Complete and email form to: exhibitorservices@paconvention.com. Once processed a payment link will be sent to the email address provided above.

INTERNET SERVICES

(Internet upload and download speeds are the same and an IP address is required for each device connected to the internet)

QTY.	SERVICE	ADVANCED RATE	STANDARD RATE	TOTAL
Dedicated Public Internet Service Dedicated Public Internet Service will accommodate internet functions such as: viewing streaming video, surfing the internet, viewing websites, and checking email. These services provide "real IP's", there are no blocked ports and they will support multiple users with VPN connections.				
	Dedicated Public 9Mb – includes (10) IP addresses, can expand to (28) total IP addresses	\$9,000.00	\$11,250.00	
	Dedicated Public 6Mb – includes (10) IP addresses, can expand to (28) total IP addresses	\$7,000.00	\$8,750.00	
	Dedicated Public 3Mb – includes (6) IP addresses, can expand to (11) total IP addresses	\$4,250.00	\$5,310.00	
	Dedicated Public 1.5Mb – includes (6) IP addresses, can expand to (11) total IP addresses	\$2,500.00	\$2,655.00	
	<i>Additional Dedicated Public IP address (Not internet service)</i>	\$160.00	\$195.00	
Dedicated Private Internet Service Private Internet Service will accommodate general internet functions such as: viewing streaming video, surfing the internet, viewing websites, and checking email. These services will not support multiple users with VPN connections.				
	Private 9Mb – includes (4) IP addresses	\$1,800.00	\$2,250.00	
	Private 6Mb – includes (4) IP addresses	\$1,200.00	\$1,500.00	
	Private 3Mb – includes (4) IP addresses	\$1,000.00	\$1,250.00	
	<i>Additional Private IP address (Not internet service)</i>	\$125.00	\$160.00	
	Dry VLAN connection – This service is not internet access. This service is inclusive of the origination and destination points. Origination Point _____ Destination Point _____	\$600	\$750	
			Subtotal	
			8% Sales Tax	
			Total	

PLEASE NOTE:

- Higher bandwidth options are available. Please contact the **Exhibitor Services department** for a quote: **215-418-2190** or exhibitorservices@paconvention.com.
- Internet service originates at back of booth. Please attach the booth floor plan if primary service is required in a location other than back of booth.
- Data cabling to multiple locations is installed by the PCC electricians. Labor and material charges will apply. Please provide data cabling distribution on floor plan.

TERMS & CONDITIONS

1. INSTRUCTION FOR COMPLETING ORDER FORM

- A. Order must be typed or clearly printed; illegible forms will delay processing.
- B. Services requested at location other than back of booth must include floor plan.
- C. For services and equipment not listed on the service order form, call the PCCA/Legends Global Exhibitor Services Department for availability and quotes at **(215) 418-2190** or e-mail **exhibitorservices@paconvention.com**

2. EXPLANATION OF SERVICE

- A. Rates shown for services are for the duration of event and include installation to exhibitor booth in the most convenient manner, in most cases to the back center of an in-line booth or perimeter of island and peninsula booths. All services originate from the floor unless otherwise noted or requested.
- B. Advance orders will be installed based on the schedule determined by the General Service Contractor and/or Show Management. On-site orders will be processed in the order that they are received at the PCC Exhibitor Services Desk.

3. RULES AND REGULATIONS FOR INTERNET SERVICE

- A. Services provided **may not be** shared by multiple exhibits.
- B. All materials and equipment furnished by Pennsylvania Convention Center and/or its sub-contractors shall remain the property of Pennsylvania Convention Center and/or its sub-contractors.
- C. Pennsylvania Convention Center and its sub-contractors are authorized to cut floor coverings to gain access to utility floor ports should this be required during installation.
- D. The use of any wireless devices including, but not limited to, wireless routers and switches that interfere with the PCC wireless frequency is prohibited.
- E. The PCC does not guarantee the routing, throughput or performance expressed or implied of any data circuits with regards to Internet access, network backbones beyond any facility we service.
- F. The PCC will not supply security services such as firewalls etc. for any data circuit we provide. It is the responsibility of exhibitors or customers to provide such security measures.
- G. The PCC requires that all devices accessing the PCC Network have the latest virus scan software, windows security updates and any other precautions necessary to protect yourself and others from viruses, malicious programs, and other disruptive applications. Any device that adversely impacts PCC's network will be disconnected from the network with or without prior notice at PCC's discretion. Additional charges may apply for troubleshooting diagnosis and/or problem resolution.
- H. All Internet and equipment will be collected within 1 hour after close of show; exhibitors are responsible for loss or damage to PCC equipment until PCC staff receives said equipment.
- I. **It is the responsibility of the client to provide the following:**
 - **Standard 10BaseT Ethernet adapter (RJ 45 Interface) for each computer.**
 - **Network Driver: TCP/IP**
 - **Proper configuration of computer equipment for TCP/IP connection.**
 - **Electrical service for your booth, room, or service location.**

4. PAYMENT TERMS & CONDITIONS

- A. **Full payment is due with service order.** Credit Card Pre-authorization for onsite charges is required when placing an order. Acceptable forms of payment are:
 - Company check (drawn on a U.S. bank) payable to **Pennsylvania Convention Center (PCC)**
 - Accepted credit cards: VISA / MASTER CARD / AMERICAN EXPRESS.**Service orders will not be processed without payment.** Exhibiting firms with outstanding balances from prior events must submit payments, otherwise services will not be provided. To pay by credit card, please contact our **Accounts Receivable Department at 215-418-4794** for assistance.
- B. Advance rates will be applicable to service orders received by PCC 21 days prior to the first day of event move-in or the deadline date noted on front of this form. Service orders received less than 21 days prior to the first day of move-in and on site will be billed at the standard rate.
- C. Third party billing is available upon request. Please contact the **PCC Finance Department on 215-418-4794** for approval.
- D. Outstanding balance for services will be automatically billed to the credit card on file.
- E. Credit will not be given for service installed and not used. Services canceled without 21-day prior written notice are subject to a cancellation fee of 25%.
- F. A \$25.00 handling charge will be assessed for returned checks due to insufficient funds.
- G. Cancellation of services must be received by PCC Exhibitor Services Department 21 days prior to the event.
- H. Claims regarding services provided by PCC will not be considered unless filed by customer issued prior to the close of show.
- I. **Refunds** of overpayments will be issued by submitting requests to PCC Finance Department within 30 days of the close of final invoice.
- J. For unpaid balances on **pre-approved** invoices, terms will be net, due and payable upon receipt of invoice. Effective 30 days after invoice date, any unpaid balances will bear a **FINANCE CHARGE** at the lower of the maximum rate allowed by law, or 1.5% per month by law. The finance charge shall automatically be reduced to the maximum rate allowed. Any excess finance charge received by the PCC shall be applied to reduce the principal unpaid balance or refund to the payer. This payment Terms & Conditions agreement shall be governed by and construed in accordance with the laws of the Commonwealth of Pennsylvania
- K. International exhibitors are required to make 100% pre-payment for services. Payment may be made by check in U.S. funds drawn on a U.S. bank or by approved credit card.
- L. For companies exempt from sales tax, PCC requires an exemption certificate for the Commonwealth of Pennsylvania. Resale certificates are not valid unless we have re-billing charges to customers.

TELECOMMUNICATIONS SERVICE ORDER FORM

(PLEASE READ TERMS AND CONDITIONS ATTACHED)

IF PAYING BY CHECK RETURN THIS FORM TO:

PCCA/LEGENDS Order Processing
1101 Arch Street
Philadelphia, PA 19107
Inquiries only: 215-418-2190
Email: exhibitorservices@paconvention.com

ACADEMY OF MANAGEMENT

**ADVANCED DEADLINE
DATE: JULY 7, 2026**

ORDERS MAY BE PLACED ONLINE AT: www.paconvention.com

Exhibiting Firm: _____ Booth No.: _____
Billing Address: _____ Event: _____
City: _____ State: _____ Zip: _____
Exhibitor Contact Name: _____ Title: _____
Phone: _____ E-Mail: _____

CREDIT CARD AUTHORIZATION REQUIRED for advance order, on-site charges, labor, and materials.

In our efforts to follow PCI compliance security guidelines and to safeguard your credit card information, we can no longer accept credit card information via this order form. Complete and email form to: exhibitorservices@paconvention.com Once processed a payment link will be sent to the email address provided above.

PHONE SERVICES (Unlimited local and long-distance calls at no additional charge)				
QTY.	SERVICE	ADVANCED RATE	STANDARD RATE	TOTAL
	Single Line Telephone Service	\$300.00	\$350.00	
	Credit Card Line/Fax Line	\$300.00	\$350.00	
	Multi Line Telephone Service	\$450.00	\$525.00	
Phone Equipment & Features				
	Conference Phone (Single Line Telephone Service must be ordered)	\$100.00	\$150.00	
	Voice Mail	\$25.00	\$25.00	
	Other:	Call for Pricing		
			Subtotal	
			8% Sales Tax	
			Total	

PLEASE NOTE:

- Phone Service originates at back of booth; please attach a floor plan if service is required in a location other than back of booth.

TERMS & CONDITIONS

1. INSTRUCTION FOR COMPLETING ORDER FORM

- A. Order must be typed or clearly printed; illegible forms will delay processing.
- B. Services requested at location other than back of booth must include floor plan.
- C. For services and equipment not listed on the service order form, call the PCCA/Legends Global Exhibitor Services Department for availability and quotes at **(215) 418-2190** or e-mail **exhibitorservices@paconvention.com**

2. EXPLANATION OF SERVICE

- A. Rates shown for services are for the duration of event and includes installation to exhibitor booth in the most convenient manner, in most cases to the back center of an in-line booth or perimeter of island and peninsula booths. All services originate from the floor unless otherwise noted or requested.
- B. Advance orders will be installed based on the schedule determined by the General Service Contractor and/or Show Management. On site orders will be processed in the order that they are received at the PCC Exhibitor Services Desk.

3. RULES AND REGULATIONS FOR SERVICES

- A. Services provided **may not be** shared by multiple exhibits.
- B. All materials and equipment furnished by PCC and/or its sub-contractors shall remain the property of PCC and/or its sub-contractors.
- C. PCC and/or its sub-contractors are authorized to cut floor coverings to gain access to utility floor ports and permit the installation of service.
- D. PCC or its sub-contractors are not responsible for interruption or fluctuation of services.
- E. All equipment provided by customer shall be compliant with the National and Philadelphia Electrical and Building Codes and PCC safety standards. All equipment is subject to inspection and approval by PCC prior to connection to service.
- F. Customer is responsible for any lost or damaged equipment supplied by the PCC.

4. PAYMENT TERMS & CONDITIONS

- A. **Full payment is due along with service order.** Credit Card Pre-authorization for onsite charges is required when placing an order. Acceptable forms of payment are:
 - Company check (drawn on a U.S. bank) payable to **Pennsylvania Convention Center (PCC)**
 - Accepted credit cards: VISA / MASTERCARD / AMERICAN EXPRESS.**Service orders will not be processed without payment.** Exhibiting firms with outstanding balances from prior events must submit payments, otherwise services will not be provided. To pay by credit card, please contact our **Accounts Receivable Department** at **215-418-4794** for assistance.
- B. Advance rates will be applicable to service orders received by PCC 21 days prior to the first day of event move-in or the deadline date noted on front of this form. Service orders received less than 21 days prior to the first day of move-in and on site will be billed at the standard rate.
- C. Third party billing is available upon request. Please contact the **PCC Finance Department** at **215-418-4794** for approval.
- D. Outstanding balance for services will be automatically billed to the credit card on file.
- E. Credit will not be given for service installed and not used. Services canceled without 21-day prior written notice are subject to a cancellation fee of 25%.
- F. A \$25.00 handling charge will be assessed for returned checks due to insufficient funds.
- G. Claims regarding services provided by PCC will not be considered unless filed by customer issued prior to the close of show.
- H. **Refunds** of overpayments will be issued by submitting request to PCC Finance Department within 30 days of the close of final invoice.
- I. For unpaid balances on **pre-approved** invoices, terms will be net, due and payable upon receipt of invoice. Effective 30 days after invoice date, any unpaid balances will bear a **FINANCE CHARGE** at the lower of the maximum rate allowed by law, or 1.5% per month by law. The finance charge shall automatically be reduced to the maximum rate allowed. Any excess finance charge received by the PCC shall be applied to reduce the principal unpaid balance or refund to the payer. This payment Terms & Conditions agreement shall be governed by and construed in accordance with the laws of the Commonwealth of Pennsylvania
- J. International exhibitors are required to make 100% pre-payment for services. Payment may be made by check in U.S. funds drawn on a U.S. bank or by approved credit card.
- K. For companies exempt from sales tax, PCC requires an exemption certificate for the Commonwealth of Pennsylvania. Resale certificates are not valid unless we have re-billing charges to customers.

WATER & COMPRESSED AIR SERVICE ORDER FORM

(PLEASE READ TERMS AND CONDITIONS ATTACHED)

IF PAYING BY CHECK RETURN THIS FORM TO:

PCCA/LEGENDS Order Processing
1101 Arch Street
Philadelphia, PA 19107
Inquiries only: 215-418-2190
Email: exhibitorservices@paconvention.com

ORDERS MAY BE PLACED ONLINE AT: www.paconvention.com

ACADEMY OF MANAGEMENT

**ADVANCED DEADLINE
DATE: JULY 7, 2026**

Exhibiting Firm: _____ Booth No.: _____
Billing Address: _____ Event: _____
City: _____ State: _____ Zip: _____
Exhibitor Contact Name: _____ Title: _____
Phone: _____ E-Mail: _____

CREDIT CARD AUTHORIZATION REQUIRED for advance order, on-site charges, labor, and materials.

In our efforts to follow PCI compliance security guidelines and to safeguard your credit card information, we can no longer accept credit card information via this order form. Complete and email form to: exhibitorservices@paconvention.com Once processed a payment link will be sent to the email address provided above.

Rate Includes Installation to Back Center of In-Line and Peninsula Booths Only. Labor & Material Required for Distribution to Other Locations, Island Booths and Connection to Equipment.				
QTY.	SERVICE	ADVANCED RATE	STANDARD RATE	TOTAL
	½" Main Airline w/ Shutoff	\$300.00	\$350.00	
	Additional ½" Airline Connection	\$115.00	\$165.00	
	½" Water line w/ Shutoff	\$210.00	\$260.00	
	Additional ½" Water line w/ Shutoff	\$115.00	\$165.00	
	¾" Drain Line	\$210.00	\$260.00	
	Additional ¾" Drain Line	\$115.00	\$165.00	
	Water Fill & Drain up to 200 gal	\$170.00	\$220.00	
	Additional 100 gal. Water Fill & Drain – Labor Additional	\$70.00	\$90.00	
	Prep Sink (Water & Drain Additional)	\$120.00	\$160.00	
	Basic Hot Water Heater Package (Includes hot/cold water lines, drain line, water heater, plumbing & electric labor at column location only). Other locations and various setups will incur additional charges.	\$1,150.00	\$1,200.00	
			Subtotal	
			8% Sales Tax	
			Total	

PLUMBING RATES		
WEEKDAYS 8 AM – 4:30 PM	WEEKDAYS AFTER 4:30 PM AND ALL DAY SATURDAY	ALL DAY SUNDAY AND HOLIDAYS
\$175.00 per hour	\$262.00 per hour	\$350.00 per hour

- Authorized to Lay Lines Under Carpet Without Exhibitor Supervision Per Attached Floor Plan
- Proceed Under Supervision Dates and Times Indicated Below:

Install Lines under Carpet: _____ Date: _____ Time: _____
Final Connection to Equipment: _____ Date: _____ Time: _____

TERMS & CONDITIONS

1. INSTRUCTION FOR COMPLETING ORDER FORM

- A. Order must be typed or clearly printed; illegible forms will delay processing.
- B. Services requested at location other than back of booth must include proper forms and diagrams.
- C. For services and equipment not listed on the service order form, call the PCCA/Legends Global Exhibitor Services Department for availability and quotes at (215) 418-2190 or e-mail exhibitorservices@paconvention.com

2. PAYMENT TERMS & CONDITIONS

- A. **Full payment is due along with service order.** Credit Card Pre-authorization for onsite charges, labor and materials is required when placing an order.

Acceptable forms of payment are:

- Company check (drawn on a U.S. bank) payable to **Pennsylvania Convention Center Authority, (PCCA)**
- Accepted credit cards: VISA / MASTERCARD / AMERICAN EXPRESS.

Service orders will not be processed without payment. Exhibiting firms with outstanding balances from prior events must submit payments, otherwise services will not be provided. To pay by credit card, please contact our **Accounts Receivable Department** at 215-418-4794 for assistance.

- B. **Advanced Rates** will be applicable to service orders received with payment in full by the deadline date noted on the front of this form.
- C. **Standard Rates** will be applicable to service orders received after the Advanced Rate Deadline or orders received without payment.
- D. **Third party billing** is available upon request. Please contact the **PCCA/Legends Global Finance Department** at 215-418-4794 for approval.
- E. **Outstanding balance** for services will be automatically billed to the credit card on file.
- F. Credit will not be given for service installed and not used.
- G. **Cancellation of services** must be received by PCC/Legends Global Exhibitor Services Department 21 days prior to the event. Services cancelled without 21 days prior written notice is subject to a cancellation fee of 25%.
- H. A \$25.00 handling charge will be assessed for returned checks due to insufficient funds.
- I. Rates are based on current wages and are subject to change without notice.
- J. **Claims** regarding services provided by PCCA/Legends Global will not be considered unless filed by customer issued prior to the close of show.
- K. **Refunds** of overpayments and dispute resolutions will be issued by submitting requests to PCCA/Legends Global Finance Department within 30 days of the close of final invoice.
- L. For unpaid balances on **pre-approved** invoices, terms will be net, due and payable upon receipt of invoice. Effective 30 days after invoice date, any unpaid balances will bear a **FINANCE CHARGE** at the lower of the maximum rate allowed by law, or 1.5% per month by law. The finance charge shall automatically be reduced to the maximum rate allowed. Any excess finance charge received by the PCCA/Legends Global shall be applied to reduce the principal unpaid balance or refunded to the payer. This payment Terms & Conditions agreement shall be governed by and construed in accordance with the laws of the Commonwealth of Pennsylvania.
- M. **International exhibitors** are required to make 100% pre-payment for services. Payment may be made by check in U.S. funds drawn on a U.S. bank or by approved credit card.
- N. For companies exempt from sales tax, PCCA/Legends Global requires an exemption certificate for the Commonwealth of Pennsylvania. Resale certificates are not valid unless we have re-billing charges to customers.

3. EXPLANATION OF SERVICE

- A. Rates shown for services are for the duration of event and include installation to exhibitor booth in the most convenient manner, in most cases to the back center of an in-line booth or perimeter of island and peninsula booths. All services originate from the floor unless otherwise noted or requested.
- B. Advance orders will be installed based on the schedule determined by the General Service Contractor and/or Show Management. On-site orders will be processed in the order that they are received at the PCC Exhibitor Services Desk.
- C. Electrical services will be turned off one hour after the close of show each day and restored one hour prior to opening.
- D. 24-hour electrical service is available for refrigeration, electronics, and circulation pumps.

4. RULES & REGULATIONS FOR SERVICES

- A. Services provided may not be shared by multiple exhibits.
- B. All materials and equipment furnished by PCC and/or its sub-contractors shall remain the property of PCC and/or its Sub-contractors.
- C. All rental equipment furnished by PCC not left in the booth at the close of the show will be charged an additional 75% of the original rental equipment charge.
- D. PCC and/or its sub-contractors are authorized to cut floor coverings to gain access to utility floor ports and permit the installation of service.
- E. PCC or its sub-contractors are not responsible for interruption or fluctuation of services.
- F. All equipment provided by customers shall be compliant with the National and Philadelphia Electrical and Building Codes and PCCA/Legends Global safety standards. All equipment is subject to inspection and approval by PCC prior to connection to service.
- G. Customer is responsible for any lost or damaged equipment supplied by the PCC.



PLUMBING SERVICES CHECKLIST

- A Convention Center Plumber must be present for all filling and draining of reservoirs, pools, tanks, ponds, or basins.
- For everyone's safety, no one, except Pennsylvania Convention Center employees, are allowed in the columns. **NO EXCEPTIONS!**
- For the safety of our guests, cable or hose ramps cannot be used in the aisles. Only in back-of-house areas when installed by show labor.
- All entities using outside sinks must have them approved by the Pennsylvania Convention Center's Utilities Department.
- Self-contained sinks must be approved by the Pennsylvania Convention Center's Utilities Department.
- Draining liquids in bathroom toilets/urinals, drinking fountains or in the electrical or plumbing ports is prohibited.
- All drainage must be approved by the Pennsylvania Convention Center's Utilities Department.
- No unauthorized attachment to airlines or plumbing lines in the columns is permitted.
- Air Compressors of any kind are not permitted in the Pennsylvania Convention Center.

EXHIBITOR SERVICES RIGGING FAQ SHEET

- Rental of Truss and Motors (including its equipment) is proprietary to PCC/ASM Global.
- Installation of all truss, motors and its equipment is performed by ASM Electricians. Labor is not included in the rental price
- See menu of sample pricing below.
- Rental Rates are based on one (1) week installments.

SILVER TRUSS ALL LENGTHS AVAILABLE



12" Silver Truss
 10' - \$100.00
 8' - \$90.00
 5' - \$70.00
 4' - \$70.00
 2' - \$70.00
 Corner Blocks—\$100.00

20.5" Silver Truss
 10' - \$120.00
 8' - \$100.00
 5' - \$ 90.00
 Corner Blocks—\$120.00

BLACK TRUSS AVAILABLE AT AN ADDITIONAL COST



12" Black Truss
 10' - \$120.00
 8' - \$110.00
 5' - \$90.00
 4' - \$90.00
 2' - \$90.00
 Corner Blocks—\$120.00

20.5" Black Truss
 10' - \$130.00
 8' - \$120.00
 5' - \$110.00
 Corner Blocks—\$130.00

STANDARD MOTOR RENTALS 1/4 TON & 1/2 TON - \$350 1 TON - \$370.00



ROTATING MOTOR \$250/RENTAL



CUSTOM RIGGING ESTIMATES ARE PREFERRED AND PROVIDED UPON REQUEST TO EXHIBITORSERVICES@PACONVENTION.COM WITH RENDERING AND/OR RIGGING PLANS.

- A 50% deposit is required with approved Rigging Estimate.
- All Electrical Suspended Elements that require electric for lights and/or rotating motors must be installed by ASM Electricians.
- All Suspended Elements that are dead hung (no lights and/or motors) are the Decorator's responsibility.
- Signage weighing 150lbs or more will traditionally require a motor(s) to be installed by ASM Electricians.
- Lights for truss can be supplied by exhibitor or 3rd party vendor, but must be installed by ASM Electricians.
- Operating of all Motor Controllers is performed by ASM Electricians.
- All booths using an EAC or Decorator supplied labor will need ASM Electricians to wire or install booth lighting.
- All rules apply to dismantle and move-out.
- For more information contact Utilities Services at exhibitorservices@paconvention.com or 215-418-4815.

1101 Arch Street, Philadelphia, PA 19107

Pennsylvania Convention Center Exhibitor Menu

Specialty Services

**Requires a dedicated 2,000 watt service, client is responsible for ordering electric

Old City Coffee Service

Espresso Service, Specialty Coffee, Tea, & Barista Service.

Contact an Aramark/SFS Sales Manager for additional information. Machine rentals are on a first come first serve basis.

Soft Pretzel Warmer**

Pretzel Warmer, \$150 daily rental
Super Pretzels, \$225 per case of 50
Served with Spicy Mustard

\$250 attendant fee for a minimum of 4 hours of service

Hosted Consumption Bar

Requires an Aramark bartender, \$250 for 2 hours of service

Contact an Aramark/SFS Sales Manager for additional information.

Keurig Machine**

Keurig Machine, \$200 per day

Includes Keurig Machine, initial 5-gallon water tank, PC condiments, cups, stirrers, beverage napkins

Box of 24 K-Cups, \$95 each

Includes four varieties

Additional 5-gallon water, \$45 each

Electric Water Cooler**

Electric Water Cooler, \$100 each

Includes cooler, 5-gallon water tank and flat bottom cups

Additional 5-gallon water, \$45.00 each

Popcorn Machine**

Popcorn Machine, \$150 daily rental

Popcorn Kit, \$140 each

Includes oil/ butte, popcorn, bags

Serves approximately 70 6-oz. bags

\$250 attendant fee for a minimum of 4 hours of service

Beverages

Coffee	<i>per gallon</i> \$78.00
Tea	<i>per gallon</i> \$78.00
Decaf	<i>per gallon</i> \$78.00
Unsweetened Iced Tea	<i>per gallon</i> \$55.00
Lemonade	<i>per gallon</i> \$60.00
Herb Infused Water	<i>per gallon</i> \$55.00
Assorted Fruit Juice	\$6.50
Bottles Water	\$5.00
Mineral Water	\$5.00
Soda	\$6.50
Powerade	\$8.00
Energy Drinks	\$8.00
Simply Juice Smoothies	\$11.50
Naked Juices	\$12.00
Saxbys Cold Brew Cans	\$12.00
5lb ice bag	\$8.50

A La Carte Items

Snacks by the Dozen

Fresh Baked Bagel Assortment with Cream Cheese, Butter & Jellies (W, M, S, SE)	\$70.00
Assorted In-House Baked European Danishes (W, E, M, SE, TN)	\$56.25
Assorted Muffins (W, M, S, SE)	\$59.50
Assorted Donuts (W, M, S, TN)	\$73.50
Assorted Breakfast Breads (W, E, M, S, TN)	\$70.50
Seasonal Whole Fruit	\$38.00
Philly Soft Pretzels (W, M)	\$44.25
Mini Soft Pretzels (W, M)	\$35.50
Assorted Prepackaged TastyKakes (W, E, M, S)	\$80.00
Assorted Prepackaged Snacks	\$34.00
Assorted Cookies (W, M, E, S)	\$40.00
Brownies (W, M, E, S)	\$42.00
Assorted Mini Cupcakes (W, M, E, S)	\$54.00
Assorted Full Size Cupcakes (W, M, E, S)	\$92.00
Assorted Prepackaged Granola Bars	\$32.50
Assorted Prepackaged Candy Bars	\$77.75
Prepackaged Quaker Caramel Rice Crisps	\$43.50
Assorted Prepackaged Pringle Snack Packs	\$82.25
Prepackaged Good Health Veggie Sticks	\$49.75
Assorted Cake Pops (W, M, E, S) **customizations available, see sales manager	\$78.00

Boxed Lunches \$38.00 each

ALL BOXED LUNCHES INCLUDE PLAIN POTATO CHIPS, COOKIE, AND BOTTLED WATER.

» ROASTED TURKEY (W, M, S, SE)

Asiago Cheese, Caramelized Onions, Spinach-Artichoke Spread, Rustic Hero

» ITALIAN COMBO (W, M, S, SE)

Hot Ham, Genoa Salami, Prosciutto, Provolone, Sun-dried Tomato Purée, Seeded Semolina Hero

» TARRAGON CHICKEN SALAD (W, E, M, S, SE)

Lettuce, Croissant

» ROAST BEEF AND CHEDDAR (W, E, M, S, SE)

Pretzel Roll, Horseradish Spread

» VEGAN SMASHED CHICKPEA WRAP (W, S)

Vegan Mayo, Red & Green Peppers, Scallions, Shredded Carrots, Green Leaf, Sun-Dried Tomato Wrap

» GRILLED VEGETABLE WRAP (S, SE)

Zucchini, Yellow Squash, Eggplant, Roasted Peppers, Hummus, Gluten Free Wrap

» GARDEN GREENS SALAD

Grape Tomatoes, Cucumbers, Green Bell Peppers, Red Onions, Red Roma Vinaigrette

ADD GRILLED CHICKEN \$5.00

This allergen key below refers to what the item contains:

Wheat (W) | Milk (M) | Egg (E) | Tree Nuts (TN) | Soy (S) | Sesame (SE) | Shellfish (SF) | Peanuts (PN)

Prepackaged items do not have allergens listed, guests can refer to the package for ingredients

Ordering Information

Ordering

Our 20-day deadline allows sufficient time to order, plan and prepare all your food and beverage needs. All orders received after the deadline will be noted as late and will be processed after all on-time orders have been completed. All original catering orders must be received **20 business days** prior to the first show day, or a 10% late charge will be applied. Changes and/or cancellations must be received 3 business days prior to the first show day. No cancellations may be made after that time. Any changes made with less than 3 business days prior to the first show date will be subject to a 20% late fee. Late changes will also be subject to approval by the Aramark/SFS Sales Department based on availability of product and staff.

Payment Policy

Aramark Corporate Policy requires full payment prior to commencement of services. Additionally, a credit card must be on file for any re-orders made on site- no exceptions. A 3% processing fee will be charged to all credit card charges.

Delivery Charge

A \$45 delivery charge will apply to all original orders subtotaling less than \$100.

Tax and Service Fee

All food and beverage pricing are subject to a 24% administrative fee and 8% tax. All equipment charges are subject to an 8% tax only.

Pricing

All prices are subject to change without prior notification.

Service Personnel

When ordering Aramark personnel for your booth, please consider set-up time. We recommend scheduling personnel one hour prior to the start of your service. Additionally, Aramark personnel will clean food and beverage related areas. They are not permitted to do general booth cleaning such as vacuuming, emptying non-food trash, dusting, etc.

Service Ware

All booth services include the appropriate variety of high-grade disposable service ware. No china service is allowed inside the exhibit halls. For any services outside of the exhibit halls, if china service is ordered, additional china charges and labor charges will apply. Please contact your Aramark/SFS Sales Manager for applicable pricing for your service.

Beverage Service

Initial beverage delivery includes- bowl of ice, ice scoop, cups, and napkins.

Tables and Electric

Aramark/SFS does not provide skirted service tables or electrical hook-ups in your exhibit space, including meeting rooms utilized for exhibits. Please contact the appropriate contractor for these items. For electrical needs, please contact Utility Services with the Pennsylvania Convention Center.

Unauthorized Food and Beverage

Aramark/SFS is the **exclusive** catering for the Pennsylvania Convention Center. Absolutely no food or beverage including candy, logo water, etc., are allowed in the Pennsylvania Convention Center without approval from Aramark/SFS and appropriate waiver/corkage fees. Contact an Aramark/SFS Sales manager for Sampling Guidelines and Corkage information.



EXHIBITOR BAR MENU

Our on-site personnel must dispense all beverages.

Bartenders are charged at \$250 for 2 hours of service and \$65 per hour per bartender will apply thereafter.

All services are provided on compostable ware.

All local taxes and fees apply. Pricing is subject to change.

Special requests are available.

Items not in our standard inventory will not be on consumption.

HOSTED CONSUMPTION BAR

SPIRITS

STANDARD SPIRITS	\$13.00
PREMIUM SPIRITS	\$14.00
SUPER PREMIUM SPIRITS	\$15.00

BEER

DOMESTIC BEER	\$8.50
IMPORTED BEER	\$9.50
NON-ALCOHOLIC BEER	\$8.50
CRAFT BEER	\$10.50
RTD CANNED COCKTAILS	\$13.00

WINE BY THE GLASS

STANDARD WINE	\$13.00
PREMIUM WINE	\$14.00
SUPER PREMIUM WINE	\$15.00
SPARKLING WINE	\$14.00

NON-ALCOHOLIC

ASSORTED SOFT DRINKS	\$6.50
BOTTLED WATER/ MINERAL WATER	\$5.00
ASSORTED FRUIT JUICES	\$6.50

Prices subject to a 24% administration fee, 8% sales tax, and 10% city liquor tax. Prices are subject to change.

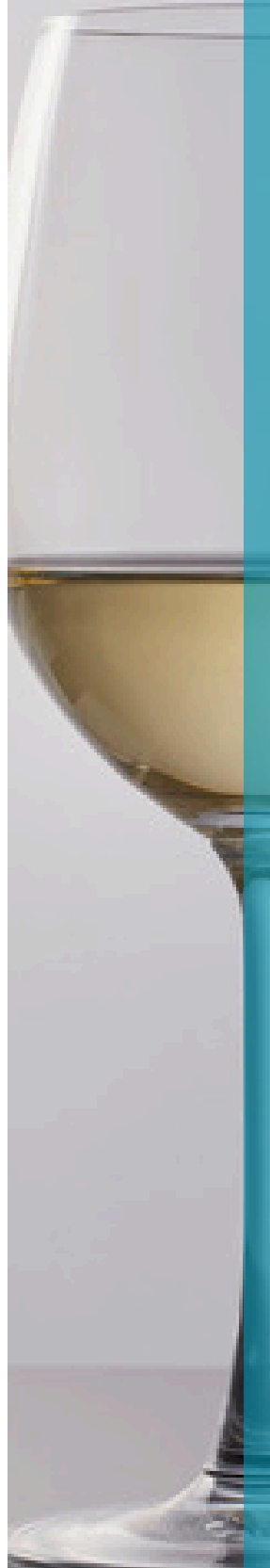



BAR MENU

Our on-site personnel must dispense all beverages.

Bartenders are charged at \$250 for 2 hours of service and \$65 per hour per bartender will apply thereafter.

All services are provided on disposable ware.

All local taxes and fees apply. Pricing is subject to change.

Special requests are available.

Items not in our standard inventory will not be on consumption.

WINE

STANDARD WINE

\$13.00

THE APPLICANT CHARDONNAY

MORANDE PRIVATE COLLECTION CABERNET

PREMIUM WINE

\$14.00

ROBERT MONDAVI PRIVATE SELECTION CHARDONNAY

ROBERT MONDAVI PRIVATE SELECTION CABERNET

SUPER PREMIUM

\$15.00

STAG'S LEAP KARIA CHARDONNAY

ROBERT MONDAVI PRIVATE SELECTION CABERNET

SPARKLING WINE

\$14.00

LA MARCO PROSECCO

KORBEL BRUT

FETE D'OR ROSE

Prices subject to a 24% administration fee, 8% sales tax, and 10% city liquor tax. Prices are subject to change.





BAR MENU

Our on-site personnel must dispense all beverages.

Bartenders are staffed 1 per 250 guests for cash bars and 1 per 100 guests for hosted/ticket bars.

Bartenders are charged at \$250.00 for 2 hours of service.

All services are provided on compostable ware.

Special requests are available.

Items not in our standard inventory will not be on consumption.

BEER

DOMESTIC BEER

MILLER LITE

YUENGLING

IMPORTED BEER

STELLA ARTOIS

MODELO

CRAFT BEER

KONA BIG WAVE

YARDS TRASH TALK IPA

WHITE CLAW [GF Black Cherry](#) or [Mango](#)

RTD COCKTAILS

STATESIDE [Black Cherry](#) or [Orange](#)

SURFSIDE ICED TEA

WINE

STANDARD WINE

THE APPLICANT CHARDONNAY

MORANDE PRIVATE COLLECTION

CABERNET

PREMIUM WINE

ROBERT MONDAVI PRIVATE SELECTION

CHARDONNAY

ROBERT MONDAVI PRIVATE SELECTION

CABERNET

SUPER PREMIUM

STAG'S LEAP KARIA CHARDONNAY

ROBERT MONDAVI PRIVATE SELECTION

CABERNET

SPARKLING WINE

LA MARCO PROSECCO

KORBEL BRUT

FETE D'OR ROSE

Prices subject to a 24% administration fee, 8% sales tax, and 10% city liquor tax. Prices are subject to change.





BAR MENU

Our on-site personnel must dispense all beverages.

Bartenders are charged at \$250 for 2 hours of service and \$65 per hour per bartender will apply thereafter.

All services are provided on disposable ware.

All local taxes and fees apply. Pricing is subject to change.

Special requests are available.

Items not in our standard inventory will not be on consumption.

LIQUOR

STANDARD LIQUOR

SVEDKA VODKA

CAPTAIN MORGAN RUM

BEEFEATER GIN

JACK DANIELS

SEAGRAMS VO WHISKEY

DEWAR'S SCOTCH

JOSE CUERVO

PREMIUM LIQUOR

TITO'S VODKA

BACARDI RUM

TANQUERARY GIN

FOUR WALLS WHISKEY

MAKER'S MARK BOURBON

JOHNNIE WALKER RED SCOTCH

1800 SILVER TEQUILA

SUPER PREMIUM LIQUOR

KETEL ONE VODKA

BACARDI 8 RUM

HENDRICKS GIN

KNOB CREEK BOURBON

HENNESSY COGNAC

JOHNNIE WALKER BLACK SCOTCH

PATRON SILVER TEQUILA

Prices subject to a 24% administration fee, 8% sales tax, and 10% city liquor tax.

Prices are subject to change.

